



# **REQUEST FOR QUOTE**

## **Block Staircase Remediation**

### **Regional District of Central Kootenay**

**Issued: August 22, 2024**

**Closing Location:**

Regional District of Central Kootenay  
Box 590, 202 Lakeside Drive  
Nelson, BC V1L 5R4

**Closing Date and Time:**

2:00pm (PST), September 5, 2024

Stuart Durning

Facility Manager

PH: (250) 236-532-2032

FX: (250) 428-5700

Email: [sdurning@rdck.bc.ca](mailto:sdurning@rdck.bc.ca)

# Table of Contents

	Page
<b>1 Invitation &amp; Instructions to Bidders.....</b>	<b>1</b>
1.1 Executive Summary .....	1
1.2 Quote Documents .....	1
1.3 Intent to Submit .....	1
1.4 Enquiries .....	1
1.5 Examination of Site(s) and Local Conditions.....	2
1.6 Quote Closing Time and Location .....	2
1.7 Quote Submissions.....	2
1.8 Ownership of Quote and Freedom of Information .....	3
1.9 RDCK’s Right to Accept or Reject Quote.....	3
1.10 No Claim for Compensation.....	4
1.11 Conflict of Interest.....	4
1.12 Anti-Collusion, Fraud & Corruption.....	4
1.13 Confidentiality.....	4
1.14 Irrevocability and Acceptance of Quote .....	4
1.15 Irregularities and Informalities .....	5
1.16 Discrepancies or Omissions .....	5
1.17 Modification of Terms/Addenda.....	5
1.18 Liability for Errors.....	5
1.19 Basis of Contract Award .....	5
1.20 Definition of Contract.....	7
1.21 Powers Preserved.....	7
1.22 Form of Contract .....	7
<b>2 Description of the Services .....</b>	<b>8</b>
2.1 Services Required .....	8
2.2 Personnel.....	8
2.3 Contractor’s Control of Supply of Services .....	8
2.4 Contractor’s Responsibilities .....	9
<b>3 General Conditions of Contract.....</b>	<b>10</b>
3.1 Definition of Terms.....	10
3.2 Period of Contract .....	12
3.3 Assignment .....	12
3.4 Insurance .....	12
3.5 Indemnity.....	14
3.6 Compliance with <i>Workers Compensation Act</i> .....	14
3.7 Health and Safety .....	15
3.8 Intent of Contract Documents .....	15
3.9 RDCK Representative’s Authority.....	15
3.10 Notice to Proceed.....	15
3.11 RDCK’s Right to Obtain Services from Other Suppliers .....	16
3.12 RDCK’s Right to Terminate the Contract .....	16
3.13 Contractor’s Right to Stop Supply of Services or Terminate the Contract .....	17
3.14 Sub-Contractors .....	18
3.15 Private Land .....	18

3.16	Dispute Resolution .....	19
3.17	Taxes and Duties .....	19
3.18	Staff Resources and Management .....	19
3.19	Right to Audit .....	20
3.20	Change in the Services .....	20
3.21	Contract Performance Reviews.....	20
3.22	Rights of Waiver .....	20
3.23	Duty of Care .....	21
3.24	Severability .....	21
3.25	Compliance with Permits, Laws and Regulations.....	21
3.26	Security for Supply of Services .....	21
3.27	Force Majeure .....	22
<b>4</b>	<b>Payment Clauses .....</b>	<b>23</b>
4.1	Payment for Services .....	23
4.2	Goods and Services Tax .....	23
4.3	Payment Withheld or Deducted .....	23
4.4	Monies Due to the RDCK .....	23
4.5	Liquidated Damages .....	24
4.6	Negotiations During Contract Term .....	24
<b>Schedules</b>		
	Quote Form	
	Schedule 1 - Description of Services	
	Schedule 2 - Pricing Schedules	
	Schedule 3 - Equipment List	
	Schedule 4 - Proposed Sub-Contractors	
	Schedule 5 - List of Previous Experience (Contracts)	
	Schedule 6 - Schedule of Addenda	
	Schedule 7 - Environmental Attributes	
<b>Appendix</b>		
	Appendix A - Site plan	
	Appendix B - Contract	

## **PART 1 – INVITATION & INSTRUCTIONS TO BIDDERS**

---

### **1 Invitation & Instructions to Bidders**

The definitions set out in Section 3.1 apply throughout this document except when expressly stipulated or the context otherwise clearly indicates.

#### **1.1 Executive Summary**

The RDCK is seeking quotes for remediation and replacement of two Allen Block staircases at the Creston & District Community Complex.

The RDCK is seeking Quotes for a Contract to supply the Services herein described on or before September 5, 2024.

#### **1.2 Quote Documents**

It is the responsibility of the Bidder to ascertain that they have received a full set of Quote documents. Upon submission of their Quote, the Bidder shall be deemed conclusively to have been in full possession of a full set of Quote Documents.

#### **1.3 Intent to Submit**

Bidders intending to submit a Quote should provide an email notification to the RDCK Representative.

A Bidder who does not submit an Intent to Submit email may not be sent any amendments or addenda.

No Bidder who sends an Intent to Submit email is obligated to submit a Quote.

#### **1.4 Enquiries**

All enquiries related to this Quote are to be directed, **in writing**, to the following person who is hereby designated as the RDCK Representative:

Stuart Durning  
Facility Manager  
Fax: 250-428-5700  
Email: sdurning@rdck.bc.ca

Information about this Request for Quote or any matter pertaining to the Services that is obtained from any source other than the RDCK Representative is not official and should not be relied upon. Enquiries

that are directed to the RDCK Representative and responses will be recorded and **MAY** be distributed to all Bidders at the option of the RDCK.

### **1.5 Examination of Site(s) and Local Conditions**

The Bidder must satisfy themselves as to the practicability of supplying the Services in accordance with the Contract, and shall be held to have satisfied themselves in every particular before submitting a Quote, by inquiry and by inspection of the Site(s) herein described.

If applicable, the Bidder should examine the Site(s) surroundings and, before submitting a Quote shall satisfy themselves as to the nature of the Site(s), the quantities and nature of the Services to be supplied and in general, shall obtain all relevant information as to risks, contingencies and other circumstances which may influence their Quote.

Bidders should make their own arrangements to visit the Site(s) indicated in Appendix A-Site Plan.

### **1.6 Quote Closing Time and Location**

Quotes will be accepted until the Closing Time and the Closing Location indicated on the cover page.

### **1.7 Quote Submissions**

Emailed and faxed Quotes will be accepted. Any Quote received after the Closing Time, or other than in the manner specified, will be considered disqualified and will be returned, unopened, to the Bidder.

A digital PDF format of the Proposal submission may be sent by e-mail to: [sdurning@rdck.bc.ca](mailto:sdurning@rdck.bc.ca)

The RDCK email server has about a 10 mb file size limit. Bidders are to ensure that they have gotten a confirmation of receipt of email prior to the closing time. Larger submissions should be broken down into 2 or more emails or arrangements should be made ahead of time for file transfer by FTP.

Bidders wishing to deliver a Quote submission in paper format to the RDCK must submit one (1) bound and one (1) unbound copy of the Quote document in a **SEALED** envelope clearly labeled "**REQUEST FOR QUOTE – BLOCK STAIRCASE REMEDIATION**".

The Bidder's name and full mailing address must be clearly marked on the outside of the response envelope.

Submissions should be accompanied by a clear indication of the anticipated schedule for the supply of the Services along with any other supporting pertinent information.

Quotes will be received until the Closing Time at the Closing Location indicated on the cover page.

Each Schedule of the Quote Form must be completed and signed by a person authorized to sign on behalf of the Bidder and authorized to bind the Bidder to any statements made in response to this Request for Quote.

1. The Bidder's name and full mailing address must be clearly marked on the outside of the response envelope.
2. The Quote must include the Quote Form.
3. The Quote must include a complete itemized pricing schedule (Schedule 2-Pricing Schedules).
4. The Quote must include a list of the equipment to be used, and in the event of a breakdown, the type of back-up equipment available (Schedule 3-Equipment List).
5. The Quote must include a list of proposed Sub-Contractors, if any (Schedule 4-Proposed Sub-Contractors).
6. The Quote must include a synopsis of all relevant experience. A list of references shall also be included with the Quote (Schedule 5-List of Previous Experience).

### **1.8 Ownership of Quote and Freedom of Information**

All responses to this Request for Quote become the property of the RDCK. By submitting a Quote the Bidder agrees the RDCK has the right to copy the Quote Documents. Quotes will be held in confidence by the RDCK, subject to the provisions of the *Freedom of Information and Protection of Privacy Act* and any requirement for disclosure of all or a part of a Quote under that Act. The requirement for confidentiality shall not apply to any Quote that is incorporated into the Contract for the supply of the Services. Further, the RDCK may disclose all or part of any Quote to the RDCK Board at a public meeting of the RDCK Board of Directors, when making a recommendation for the award of the Contract.

### **1.9 RDCK's Right to Accept or Reject Quote**

The lowest or any Quote will not necessarily be accepted. The RDCK reserves the right in its absolute discretion to: accept the Quote which it deems most advantageous and favourable in the interests of the RDCK; and waive informalities in, or reject any or all Quotes, in each case without giving any notice. In no event will the RDCK be responsible for the costs of preparation or submission of a Quote.

If there is only one compliant Quote received by the Closing Time, the RDCK reserves the right to accept the Quote or cancel the Quote process with no further consideration for the sole Quote. This includes the right to cancel this Request for Quote at any time prior to entering into the Contract with the Contractor. The RDCK reserves the right to cancel this Request for Quote at any time before execution of the Contract without being obligated to any Bidder regardless of whether there is one or more compliant Quotes.

Quotes that contain qualifying conditions or otherwise fail to conform to these Instructions to Bidders may be disqualified or rejected by the RDCK in its absolute discretion. The RDCK may at its sole discretion reject or retain for consideration Quotes which are non-conforming including Quotes that do not conform because they do not contain the content or form required by these Instructions to Bidders or because they have not complied with the process for submission set out herein.

### **1.10 No Claim for Compensation**

Except as expressly and specifically permitted in these Instructions to Bidders, no Bidder shall have any claim for any compensation of any kind whatsoever, as a result of participating in the Request for Quote, and by submitting a Quote each Bidder shall be deemed to have agreed that it has no claim.

### **1.11 Conflict of Interest**

By submitting a Quote, the Bidder warrants that neither it nor any of its officers or directors, or any employee with authority to bind the Bidder has any financial or personal relationship or affiliation with any elected official or employee of the RDCK or their immediate families which might in any way be seen (in the RDCK's sole and unfettered discretion) to create a conflict.

### **1.12 Anti-Collusion, Fraud & Corruption**

The Bidder shall not communicate to any person prior to the opening of Quotes (other than to the RDCK through the delivery of a Quote in the prescribed manner) the amount of any Quote, or at any time adjust the amount of any Quote by arrangement with any other persons, make any arrangement with any other person about whether or not they or that other person should or should not submit a Quote or otherwise collude with any other person in any manner whatsoever in the Quote process.

Any breach of this provision or non-compliance on the part of a Bidder shall, without affecting the Bidder's liability for such breach or non-compliance, result in the Quote's disqualification.

### **1.13 Confidentiality**

Confidential information about the RDCK obtained by Bidders must not be disclosed unless authorized to do so, in writing, by the RDCK. The Bidder agrees that their obligation of confidentiality will survive the termination of any Contract awarded under this Quote process.

### **1.14 Irrevocability and Acceptance of Quote**

After the Closing Time, all Quotes are irrevocable. By submission of a Quote, the Bidder agrees that should its Quote be successful the Bidder will enter into the Contract with the RDCK for the supply of the Services. The Contract shall be on the terms and conditions set out in this Request for Quote and as set out in Appendix B. Each Quote will be irrevocable and open for acceptance by the RDCK for a period of ninety (90) calendar days from the day following the Quote Closing Time, even if the Quote of another Bidder is accepted by the RDCK.

By submission of a clear and detailed written notice the Bidder may amend or withdraw its Quote PRIOR to the Closing Time. Notice in writing must be submitted to the RDCK Representative.

### **1.15 Irregularities and Informalities**

The RDCK reserves the right, at its sole discretion to waive irregularities and informalities in any Quote and to seek clarification or additional information on any area of any Quote when it is in the best interest of the RDCK to do so.

### **1.16 Discrepancies or Omissions**

Bidders finding discrepancies or omissions in the Specifications or other documents or having any doubts on the meaning or intent of any part thereof should immediately request, in writing, clarification from the RDCK Representative who will send written instructions or explanations to all parties having a set of the Quote Documents in accordance with section 1.4. Any work on a Quote done by the Bidder after the discovery of discrepancies, errors or omissions, which the Bidder fails to seek clarification about, shall be done at the Bidder's risk.

### **1.17 Modification of Terms/Addenda**

The RDCK reserves the right to modify the terms of this Request for Quote at any time before the Closing Time in its sole discretion. Written Addenda are the only means of amending or clarifying any of the information contained in the information package. The RDCK may amend or clarify the information package by issuing an Addendum. No employee or agent of the RDCK is authorized to amend or clarify the content of the information package or any Addenda except by issuing an Addendum. The RDCK makes no guarantee as to the timely delivery of any Addendum. Addenda issued prior to closing of this Invitation to Quote shall become a part of the Quote Documents.

### **1.18 Liability for Errors**

While the RDCK has used considerable efforts to ensure an accurate representation of information in this Request for Quote, the information contained in this Request for Quote is supplied solely as a guideline for Bidders. The information is not guaranteed or warranted to be accurate by the RDCK, nor is it necessarily comprehensive or exhaustive. Nothing in this Request for Quote is intended to relieve the Bidders from forming their own opinions and conclusions with respect to the matters addressed in this Request for Quote.

### **1.19 Basis of Contract Award**

Bidders are hereby notified that the RDCK intends to review and enter into the Contract for the supply of the Services based not only on the Quote price, but the Bidder's experience and qualifications considered essential by the RDCK to provide the Services requested and any other criteria the RDCK considers relevant in its absolute discretion, including the following:

- a) the qualifications and experience necessary for the satisfactory performance of the assignment;
- b) the capacity of the Bidder to supply the Services promptly;



- c) the performance of the Bidder on similar projects, record of compliance with all statutes, regulations, and bylaws affecting the Bidder's previous supply of Services;
- d) a positive reference referral from previous experience;
- e) lowest price to the RDCK of having the Services supplied in accordance with the Request for Quote documents;
- f) proposed rebate for commodity value to the RDCK, including comprehensiveness, transparency, ease of tracking price fluctuations, and ease of verifying Contractor's invoice information;
- g) environmental attributes of a Bidder's Quote;
- h) conformity of the Quote to the requirements set forth in the description of Services; and
- i) conformance with the timing provided for in the Description of Services.

The RDCK, when considering the award of the Contract, will take the above prerequisites and the Quote schedules into consideration.

Bidders shall be competent and capable of supplying the Services. Bidders may be required to provide further evidence of previous experience and financial responsibility as outlined in Schedule 5-List of Previous Experience. A reference check on past experience may be performed.

The evaluation process will be conducted solely at the discretion of the RDCK. The RDCK may decide to utilize other criteria in the review of Quotes other than those set forth above; in particular, the price to supply the Services may not be the only or primary criterion that will be utilized by the RDCK. The RDCK reserves the right to make inquiries regarding any or all Quotes and to verify all information submitted by Bidders.

The RDCK reserves the right, at its discretion, to negotiate with any Bidder that the RDCK believes has the most advantageous Quote or with any other Bidder or Bidders concurrently. In no event will the RDCK be required to offer any modified terms to any other Bidder prior to entering into the Contract with the successful Bidder, and the RDCK shall incur no liability to any other Bidder as a result of such negotiations or modifications.

Bidders are advised that, after receipt of Quotes and prior to award of Contract, Bidders may be required to provide the RDCK with additional information concerning the Bidder or their Quote including, but not limited to, a further breakdown of relevant components of the proposed prices.

The RDCK reserves the right to reject any Quotes of a company that is, or whose principals are, at the time of submitting a Quote, engaged in a lawsuit against the RDCK in relation to the supply of goods or services.

The RDCK reserves the right to reject any Quotes of a company that owes, or whose principals owe, monies to the RDCK at the time of submitting a Quote.

## **1.20 Definition of Contract**

This Request for Quote should not be construed as an Agreement or Contract to purchase goods or services. The RDCK is not bound to enter into the Contract with the Bidder who submits the lowest priced Quote or with any Bidder. The RDCK will be under no obligation to receive further information, whether written or oral, from a Bidder after the Quote Closing Time.

Neither the acceptance of a Quote nor the execution of the Contract will constitute approval of any activity or development contemplated in any Quote that requires any approval, permit or license pursuant to any federal, provincial, regional district or municipal enactments.

Notice in writing to a Bidder that it has been identified as the Contractor and the subsequent full execution of a written agreement will constitute the Contract for the supply of the Services and no Bidder will acquire any legal or equitable rights or privileges relative to the supply of the Services until the occurrence of both such events.

## **1.21 Powers Preserved**

Except as expressly set out in this Agreement, nothing in this Request for Quote shall prejudice or affect the rights and powers of the RDCK in the exercise of its powers, duties or functions under the Community Charter or the Local Government Act or any of its bylaws, all of which may be fully and effectively exercised as if this Agreement had not been executed and delivered.

## **1.22 Form of Contract**

By submission of a Quote, the Bidder agrees that, should it be identified as the successful Bidder, it is willing to enter into the Contract detailed in Appendix B with the RDCK within fifteen (15) days of the date of the Notice of Award. The Contract will include of all documents listed below:

- Notice to Proceed
- Contract Agreement
- Part 2 - Description of the Services
- Part 3 - General Contract Conditions
- Part 4 - Payment Clauses
- Part 5 - Contract Form
- Schedule 1 - Description of Services
- Schedule 2 - Pricing Schedules
- Schedule 3 - Equipment List
- Schedule 4 - Proposed Sub-Contractors
- Schedule 5 - List of Previous Experience (Contracts)
- Schedule 6 - Schedule of Addenda
- Schedule 7 - Environmental Attributes
- Certificates of Insurance
- WorkSafe BC Clearance Letter

By submission of a Quote, the Bidder agrees that, should it be identified as the Contractor, it is willing provide to the RDCK the necessary Insurance Policies and WorkSafe BC Clearance Letter within fifteen (15) days of the date of the Notice of Award.

## **PART 2 – DESCRIPTION OF SERVICES**

### **2 Description of the Services**

This Part shall be read with and shall form part of the Contract to be executed by the parties.

#### **2.1 Services Required**

The Services to be supplied to the RDCK consist of the following: Demolition and re-construction of 2 modular brick staircases – replacing modular brick stairs with formed concrete. A detailed description of the Services and relevant Specifications is set out in Schedule 1.

#### **2.2 Personnel**

The Contractor shall, at all times during the term of the Contract, employ a Supervisor charged with the responsibility of supervising the operations of the Contractor. The Supervisor shall represent the Contractor for the supply of the Services, and directions given to him by the RDCK shall be held to have been given to the Contractor. Contact information for the Supervisor shall be given to the RDCK, and the Supervisor shall respond promptly to all requests by the RDCK.

The Contractor shall employ properly qualified and trained equipment operators, labourers and supervisory staff to supply the Services. The Contractor acknowledges that its employees, agents and sub-contractors may come into contact with the public in the execution of the Contract and that it is of primary importance to the RDCK that excellent relations with the public be maintained. All personnel performing work under the Contract shall conduct themselves in a courteous and polite manner towards the public. All Contractor personnel shall wear reflective safety vests and approved safety footwear (or a garment with similar reflective qualities) at all times while performing work under the Contract.

All Contractor personnel shall respond appropriately to environmental management issues that arise during performance of their duties in respect of the supply of the Services (responding to spills, managing found hazardous materials, etc.).

#### **2.3 Contractor's Control of Supply of Services**

The Contractor shall have complete control in respect of the supply of the Services and shall effectively direct and supervise the supply of the Services using its best skill and attention. The Contractor shall be

solely responsible for all means, methods, techniques, sequences and procedures required for the supply of the Services and for coordinating all parts of the supply of the Services under the Contract.

The Contractor shall carefully examine the Contract Documents and shall promptly report to the RDCK Representative any error, inconsistency or omission they may discover. Although the RDCK may agree to special methods of supplying the Services, the Contractor will not be relieved of their responsibility for the result. The RDCK's agreement with such special methods shall not constitute ground for claims for the Contractor for any additional payment, nor for relief of their responsibility for the methods used.

#### **2.4 Contractor's Responsibilities**

All equipment, labour, materials and associated costs for the supply of the Services will be the responsibility of the Contractor. The Contractor shall have the required expertise to supply the Services in a competent manner. The Contractor's responsibilities shall include, but not be limited to the following:

- a) The Contractor shall safeguard workers by ensuring clean, functional clothing, protective gloves and footwear, in accordance with Worker's Compensation Board regulations, is worn during the performance of the Contract.
- b) The Contractor shall present a positive image to residents by using clean, attractively painted, well maintained vehicles. The Contractor's vehicles shall be maintained in a clean, functional and operational condition with reference to relevant health or sanitary regulations.
- c) The Contractor shall prominently display their name, telephone number and vehicle identification number on each vehicle to be used in the performance of the Contract.

## **PART 3 – GENERAL CONTRACT CONDITIONS**

---

### **3 General Conditions of Contract**

This Part shall be read with and shall form part of the Contract to be executed by the parties.

#### **3.1 Definition of Terms**

The following words and terms, unless the context dictates otherwise, shall have the following meanings. Words having a singular number include the plural and vice versa. References to the male gender refer to the female gender as well when appropriate.

**“Addenda” or “Addendum”** means any addenda or addendum to this Request for Quote pursuant to section 1.17.

**“Agreement” or “Contract”** means the written Agreement resulting from this Request for Quote to be executed by the RDCK and the successful Bidder as Contractor as described in section 1.22 and on the terms set out in this Request for Quote and Appendix B.

**“Bidder”** means the individual, partnership, corporation or combination thereof, including joint ventures, who or which sign the Quote submission.

**“Closing Location”** means the location described in section 1.6 of these Instructions to Bidders.

**“Closing Time”** means the Closing date and time described in section 1.6 of these Instructions to Bidders.

**“Contract Documents”** means the Contract, the Contractor’s Quote Documents, the Request for Quote documents and such other documents as listed in the Contract, including all amendments and addenda agreed to between the parties.

**“Contract Price”** means the price to be paid by the RDCK for the supply of Services under the Contract.

**“Contractor”** means the successful Bidder who may be an individual, partnership, corporation or combination thereof, including joint venture, who or which executes the resulting Contract.

**“Force Majeure”** shall mean any event or circumstance, excluding lack of funds and labour disruptions, not within the reasonable control of the party claiming the

Force Majeure, which prevents or delays that party from meeting an obligation hereunder, and which that party has not been able to overcome by the exercise of due diligence, and including:

- (a) acts of God, including wind, ice and other storms, lightning, floods, earthquakes, volcanic eruptions and landslides;
- (b) epidemics, war (whether or not declared), blockades, acts of public enemies, acts of sabotage or terrorism, civil insurrections, riots and civil disobedience;
- (c) explosion or fire;

<b>“G.S.T”</b>	means the Good and Services Tax administered under the <i>Excise Tax Act</i> (Canada) and any successor tax or levy in force from time to time.
<b>“Instructions to Bidders”</b>	means all instructions, requirements, terms and conditions of this Request for Quote and any addenda thereto.
<b>“Intent to Submit”</b>	means the email notification to the RDCK described in section 1.3 of this Request for Quote.
<b>“Irrevocable Commercial Letter of Credit”</b>	means the Irrevocable Commercial Letter of Credit described in section 3.26.
<b>“Notice of Award”</b>	means the notice of award of the Contract to the Bidder under this Request for Quote.
<b>“Notice to Proceed”</b>	means the notice described in section 3.10.
<b>“P.S.T”</b>	means British Columbia Provincial Sales Tax and any successor tax or levy in force from time to time, including but not limited to the Services and Services Tax.
<b>“Quote”</b>	means the Bidder’s submission.
<b>“RDCK”, “Regional District”</b>	means the Regional District of Central Kootenay, a corporation under the <i>Local Government Act</i> having its offices and postal address at Box 590, 202 Lakeside Drive, Nelson, BC V1L 5R4.
<b>“RDCK Representative”</b>	means the person designated in section 1.4 of this Request for Quote.
<b>“Requirements”</b>	means all of the requirements set out in the Request for Quote and Instructions to Bidders, Description of Services, General Contract

Conditions, Payment Clauses and elsewhere in the Agreement that describes the requirements for the supply of the Services.

- “Services”** means all goods or services to be supplied under this Request for Quote and all else necessary for the execution, completion and fulfillment of the Requirements and as described in section 2.1 of this Request for Quote.
- “Site(s)”** means, if applicable, the place where the Services are to be supplied or undertaken by the RDCK, namely Creston & District Community Complex, as shown in Appendix A.
- “Specifications”** means the requirements for and technical descriptions of the Services as detailed in Schedule 1.
- “Sub-Contractor”** means any sub-contractor of the Bidder, including those Sub-Contractors listed in Schedule 4.
- “Supervisor”** means the supervisor employed by the Contractor pursuant to section 2.2.

### **3.2 Period of Contract**

The Contract to be awarded as a result of this Request for Quote shall commence on September 23, 2024.

The aforesaid Contract shall terminate on December 31, 2024.

The Contract may be extended for up to 6 months by mutual agreement of both parties.

### **3.3 Assignment**

The Contractor shall not sublet, sell, transfer, assign, or otherwise dispose of the Contract, any portion thereof, or their right, title, or interest therein, or their obligations there under without written consent of the RDCK which consent may be withheld unreasonably, except for an assignment to a bank of the payments to be received by the Contractor from the RDCK.

### **3.4 Insurance**

Any Contract resulting from this RFP will require that the Contractor, without limiting its obligations or liabilities and at its own expense, provide **and maintain throughout the Contract term**, the following insurances and such other insurance coverage as the RDCK may reasonably require with insurers licensed in the Province of British Columbia. The Contractor must have their broker complete the RDCK Standard Certificate of Insurance form and provide the completed form to the RDCK, confirming proof of

the insurance requirements below upon execution of this Agreement.

- (a) Automobile Liability (third party) insurance with a minimum limit of \$5,000,000.
- (b) comprehensive commercial general liability insurance against claims for bodily injury, death or property damage arising out of this Agreement or the provision of the Services in the amount of \$ **5,000,000 dollars per occurrence** with a **maximum deductible of \$5,000**;

Such insurance will:

- (i) name the Regional District, its elected officials, employees, officers, agents and others as an additional insured;
  - (ii) include the Contractor's Blanket contractual liability;
  - (iii) include a Cross Liability clause;
  - (iv) include occurrence property damage;
  - (v) include personal injury;
  - (vi) include a Waiver of Subrogation clause in favor of the RDCK whereby the insurer, upon payment of any claim(s), waives its right to subrogate against the RDCK for any property loss or damage claim(s);
  - (vii) be primary in respect to the operation of the named insured pursuant to the contract with the RDCK. Any insurance or self-insurance maintained by the RDCK will be in excess of such insurance policy (policies) and will not contribute to it;
  - (viii) require the insurer not cancel or materially change the insurance without first giving the RDCK thirty days' prior written notice; provided that if the Contractor does not provide or maintain in force the insurance required by this Agreement, the Contractor agrees that the RDCK may take out the necessary insurance and the Contractor shall pay to the RDCK the amount of the premium immediately on demand.
- (c) course of construction/builders risk coverage in the amount of **full replacement value of project + 10%** with a maximum \$10,000 deductible;
  - (d) all risk property coverage in an amount sufficient to cover the cost of the contractor's equipment and tools needed for this contract, as well as work product in progress prior to delivery.

The Contractor shall provide proof of insurance coverage on each anniversary date of the Contract.



### **3.5 Indemnity**

The Contractor shall indemnify and save harmless, the RDCK, from and against any and all losses and all claims, demands, payments, losses, costs, damages suits, actions, recoveries, and judgments brought or recovered against them and/or the RDCK by reason of this Request for Quote or any act or omission of the Contractor, its Sub-Contractors, agents, or employees, in the supply or provision of the Services and otherwise in the performance of or failure to perform the Contract, which shall include protecting the Services and protecting the public from hazards arising out of the supply of the Services.

The obligation of the Contractor under this Section shall apply only to the extent that losses, claims, demands, payments, costs, damages suits, actions, recoveries, and judgment claims do not arise solely out of a negligent act or omission of the RDCK, other Contractors or Representatives of the RDCK, as duly appointed by the RDCK.

### **3.6 Compliance with *Workers Compensation Act***

The Contractor shall ensure compliance, on their part and on the part of all of their Sub-Contractors, with the *Workers Compensation Act* and the Occupational Health and Safety Regulations thereunder.

Prior to supplying any of the Services in the Contract, the Contractor must provide the RDCK with the Contractor's WorkSafe BC number, and must pay and keep current during the term of the Contract, all assessments required by WorkSafe BC in relation to the supply of the Services or the Contract Price. In any case where pursuant to the provisions of the *Workers Compensation Act*, an order is given to the Contractor, or one of their Sub-Contractors in respect to their operations under the Contract to cease operations because of failure to install or adopt safety devices or appliances or methods as directed, or required by the *Workers Compensation Act* or Regulations there under, or because conditions of immediate danger exist that would be likely to result in injury to any person, and the Contractor is not available or capable of removing the danger to life or equipment resultant from the Contractor's operations then the RDCK may issue a Written Notice to the Contractor and may immediately arrange for the removal of this danger and the Contractor shall be liable for the costs of such arrangements, but such act by the RDCK shall not relieve the Contractor of responsibility for injury, loss of life, or damage which may occur in that situation.

In the event that the Contractor refuses or fails to comply with an order under the *Workers Compensation Act* or Regulations thereunder, so that the supply of the Services is stopped, the RDCK may, upon written notice, terminate the Contract and proceed in accordance with Section 3.12-RDCK's Right to Terminate the Contract.

The Contractor shall, during the term of the Contract, maintain Workers Compensation Insurance in order to fully protect both its employees and the RDCK as may be required by law during the term of the Contract and shall on each anniversary date of the Contract, provide the RDCK with proof of payment of claims in good standing with WorkSafe BC by way of a WorkSafe BC Clearance Letter.

### **3.7 Health and Safety**

The Contractor shall be solely and completely responsible for ensuring safety of all persons and property during the supply of the Services. This requirement shall apply during the Contract period and not be limited to normal working hours.

The Contractor shall be liable for any and all injury or damage which may occur to persons or to property due to any act, omission, neglect or default of the Contractor, or of their employees, workmen or agents.

The Contractor shall satisfy the Manager that a safety program has been developed in accordance with the Occupational Health and Safety Regulations, and Safe Work Practices and Procedures of WorkSafe BC and shall incorporate all of the RDCK's operating requirements and restrictions.

The Contractor shall assign an individual responsible and authorized to supervise and enforce compliance with all safety regulations required in the supply of the Services.

### **3.8 Intent of Contract Documents**

The intent of the Contract Documents is that the Contractor shall provide all materials, supervision, labour, equipment and all else necessary for or incidental to the proper supply of the Services described in the Specifications and all incidental work to supply the Services. This is not an Agreement of employment. The Contractor is an independent Contractor and nothing herein shall be construed to create a partnership, joint venture or agency and neither party shall be responsible for the debts or obligations of the other.

### **3.9 RDCK Representative's Authority**

The RDCK Representative will observe the supply of the Services in progress on behalf of the RDCK. The RDCK Representative will have the authority to stop the supply of the Services whenever such stoppage may be necessary, in their opinion, to ensure the proper supply of the Services in accordance with the provisions of the Contract.

### **3.10 Notice to Proceed**

Following the execution of the Contract by the Contractor and the provisions of the required Irrevocable Commercial Letter of Credit and insurance policies, a written Notice to Proceed with the supply of the Services will be given to the Contractor by the RDCK. The Contractor shall supply the Services at the time specified in the Contract or, if applicable, begin supplying the Services on the first day of the Term and shall proceed with the supply of the Services regularly and without interruption thereafter throughout the Term, unless otherwise directed in writing by the Manager or RDCK.

### **3.11 RDCK's Right to Obtain Services from Other Suppliers**

If the Contractor should refuse or fail to supply adequate workmanship, products, or machinery and equipment for the scheduled supply of the Services, or neglects to supply the Services properly, or fails to perform any of the provisions of the Contract, then the RDCK, without prejudice to any of its other rights under the Contract, may notify the Contractor in writing, that the Contractor is in default of their contractual obligations, and instruct him to correct the default within forty-eight (48) hours.

If the correction of the default cannot be completed within forty-eight (48) hours as specified, the Contractor shall be considered to be in compliance with the RDCK's instruction if it commences the correction of the default within the specified time, and in addition provides the RDCK with a schedule that is acceptable to the RDCK in its sole discretion for such correction and completes the corrections in accordance with such schedule.

If the Contractor fails to comply with the provisions of this section the RDCK may, without prejudice to any other right or remedy they may have, obtain the supply of Services from another supplier and may deduct the cost thereof from the payment then or thereafter due the Contractor, or may without notice to the Contractor deduct the cost from the amount secured under the Irrevocable Commercial Letter of Credit.

### **3.12 RDCK's Right to Terminate the Contract**

If the Contractor should:

- a) be adjudged bankrupt, or make a general assignment for the benefit of creditors, or if a receiver is appointed on account of their insolvency, or
- b) fail to make sufficient payments due to their Sub-Contractors, or suppliers, or
- c) disregard laws or regulations that apply to the supply of the Services, or the RDCK's instructions, or
- d) abandon the supply of the Services, or
- e) otherwise violate the conditions of the Contract, the RDCK shall, by written notice, instruct the Contractor to correct the default within forty-eight (48) hours.

If the default is not corrected within forty-eight (48) hours, then the RDCK may, without prejudice to any other right or remedy they may have, terminate the Contract. If notice has been given to the Contractor under Article 3.11-RDCK's Right to obtains Services from other suppliers, then a further notice and time to correct the default is not required and that in addition to correcting the default RDCK may without further notice proceed to terminate the Contract.

If the RDCK terminates the Contract under the conditions set out above, the RDCK shall be entitled to:

- a) obtain the supply of the Services by whatever method is deemed expedient but without undue delay or expense;
- b) withhold any further payments to the Contractor until the supply of the Services is finished;

- c) upon completion of the supply of the Services, determine the full cost of obtaining the supply of the Services including compensation to the RDCK for this additional service and a reasonable allowance to cover the costs of any corrections required under the guarantee, and charge the Contractor the amount by which the full cost exceeds the unpaid balance of the Contract Price; or if such cost of obtaining the supply of the Services is less than the unpaid balance of the Contract Price, pay the Contractor the difference; or if such cost of finishing the supply of the Services is greater than the unpaid balance deduct the difference from the Irrevocable Commercial Letter of Credit.

It is also understood and agreed by and between the parties to the Contract, that in the event of a strike or lockout of the employees of the RDCK taking place during the term of the Contract, during which the supply of the Services may be interrupted or blocked, that the provisions of the Contract requiring payment by the RDCK to the Contractor shall be renegotiated on the basis of the Contractor's actual proven costs for the period.

It is also understood and agreed by and between the parties to the Contract, that in the event of a strike or lockout of the employees of the Contractor taking place during the term of the Contract, during which the supply of the Services may be interrupted or blocked, that the RDCK shall at its option and without penalty or further payment to the Contractor, have the right to unilaterally terminate the Contract, and to remove the Contractor, their employees and equipment from the Site.

### **3.13 Contractor's Right to Stop Supply of Services or Terminate the Contract**

If the supply of the Services should be stopped or otherwise delayed for a period of ninety (90) days or more under an order of any court, or other public authority, and provided that such order was not issued as the result of any act or fault of the Contractor or of anyone directly or indirectly employed by him, the Contractor may, without prejudice to any other right or remedy they may have, by giving the RDCK written notice, hold the RDCK in default.

The Contractor may notify the RDCK in writing that the RDCK is in default of its contractual obligations if the RDCK, subject to requirements of these Contract General Conditions fails to pay to the Contractor when due, any amount due and owing to the Contractor under the Contract. Such written notice shall advise the RDCK that if such default is not corrected within thirty (30) calendar days from the receipt of the written notice the Contractor may, without prejudice to any other right or remedy it may have, stop the supply of the Services and terminate the Contract.

If the Contractor terminates the Contract under the conditions set out above, they shall be paid for all Services supplied and for any loss sustained upon products and construction machinery and equipment, with reasonable profit up to the time that the Contract is terminated. If the Contractor terminates the Contract this is their sole remedy and the RDCK will not be liable for any additional costs or for any loss of profit following termination.

### **3.14 Sub-Contractors**

The Contractor agrees to preserve and protect the rights of the RDCK with respect to any supply of Services or work performed under the Contract and shall:

- a) enter into Contracts or written Agreements with the Sub-Contractors requiring them to supply Services and perform work in accordance with and subject to the terms and conditions of the Contract Documents; and
- b) be as fully responsible to the RDCK for acts and omissions of the Sub-Contractors and of persons directly or indirectly employed by them as for acts and omissions of persons directly employed by the Contractor.

The Contractor therefore shall incorporate all terms and conditions of the Contract General Conditions into all Sub-Contract Agreements they enter into with their Sub-Contractors, insofar as they are applicable.

The Contractor agrees to employ only those Sub-Contractors proposed by him in writing in Schedule 4-Proposed Sub-Contractors, and accepted by the RDCK for such portions of the supply of the Services as may be designated.

The RDCK may, for reasonable cause, object to the use of a proposed Sub-Contractor and require the Contractor to employ another that is acceptable to the RDCK. Under these circumstances, the RDCK will advise the Contractor, in writing, of its objection to a Sub-Contractor. The Contractor shall provide the names of alternate Sub-Contractors for that part of the supply of the Services, each of whom must be acceptable to the RDCK. The Contractor and the RDCK will then agree as to which new Sub-Contractor shall be used.

Nothing contained in the Contract General Conditions shall create any contractual obligation between any Sub-Contractor and the RDCK.

Sub-Contractors shall not further sub-contract any portion of the supply of the Services that is the subject of their sub-contract without prior written approval of the RDCK, which may not be withheld unreasonably.

### **3.15 Private Land**

If applicable, it shall be the Contractor's responsibility to ascertain the boundaries within which the supply of Services must be confined. The Contractor shall not enter upon lands other than those provided by the RDCK for any purpose without obtaining prior written permission of the land-owners and occupiers. A copy of the written permission is to be provided to the RDCK prior to entry upon private lands.

The Contractor shall not enter upon lands owned by others on which the RDCK has easements or rights-of-entry without having received the prior written authorization of the RDCK for such entry. It shall be

the Contractor's responsibility to ascertain from the RDCK the conditions on which easements of rights-of-entry have been granted on private lands and to abide by these conditions throughout.

### **3.16 Dispute Resolution**

All claims, disputes or issues in dispute between the RDCK and the Contractor shall be decided by mediation or arbitration if the parties agree, or failing agreement, in a court of competent jurisdiction within the Province of British Columbia. All procedures for the resolution of disputes arising in relation to the Contract shall be governed by the laws of British Columbia, Canada.

In the event that the parties agree to arbitration, the arbitration shall be governed by the rules of the British Columbia International Arbitration Centre, except that the Arbitrator(s) shall be agreed upon by the parties, and failing agreement by the parties, shall be appointed by a court of competent jurisdiction within the Province of British Columbia, Canada.

Arbitration will take place in the Southern Interior of British Columbia and be governed by the laws of the Province of British Columbia, Canada.

### **3.17 Taxes and Duties**

The Contractor shall pay all government sales taxes, customs duties and excise taxes with respect to the Contract including but not limited to any GST or PST. The Contractor is required to identify any applicable tax separately on all invoices and the RDCK is liable to pay this amount to the Contractor. Where an exemption of government sales taxes, custom duties or excise taxes is applicable to the Contract by way of the Contractor filing claims for, or cooperating fully with the RDCK and the proper authorities in seeking to obtain such refunds, the procedure shall be established in a Supplementary Condition.

### **3.18 Staff Resources and Management**

The Contractor shall, at all times during the term of the Contract, have a Supervisor charged with the responsibility of supervising the operations of the Contractor and shall maintain a local office at all times and a telephone staffed during all working hours throughout the duration of the Contract.

The Contractor shall employ properly qualified and trained equipment operators, labourers and supervisory staff for the operation of the Contract and shall make available a sufficient number of staff to complete the supply of the Services. Failure or delay in the performance of the Contract due to the Contractor's inability to obtain personnel of the number and skill required shall constitute a default of the Contract.

The Contractor shall ensure that no person will be discriminated against because of race, colour, sex, age, religion or origin. Wages and hours of labour employed shall be in accordance with all applicable federal, provincial and municipal enactments. The Contractor shall, at all times, enforce discipline and good order among their employees, and shall not employ on the Site any unfit person or anyone not skilled in the

work assigned to them. Any persons employed on the Site, who become intoxicated, intemperate, disorderly, incompetent or willfully negligent, shall, at the written request of the RDCK Representative, be removed from the Site and shall not be employed again in any portion of the supply of the Services without the approval of the RDCK Representative.

### **3.19 Right to Audit**

Upon reasonable notice the Contractor and/or any Sub-Contractors shall provide the RDCK and its internal auditors, external auditors, its regulators and such other entities/persons as the RDCK may designate, with unrestricted access at reasonable times to the data and records relating to the supply of the Services, including but not limited to the Contractor's marketing and sale of the recyclable material, the amounts charged to the RDCK by the Contractor, and the amounts of any commodity value rebates that are payable. Such access will be provided in order to verify the accuracy of charges and invoices for the Services supplied.

### **3.20 Change in the Services**

The RDCK, without invalidating the Contract, may make changes by altering, adding to, or deducting from the Services. The Contractor shall proceed with the supply of the Services as changed and the Services shall be supplied under the provisions of the Contract. No changes shall be undertaken by the Contractor, without written order from the RDCK, except in an emergency endangering life or property, and no claims for additional compensation shall be valid unless the change in writing was so ordered.

If such changes affect the requirements of the Contract, they will be so specified at the time of ordering the changes. The value of the addition or deduction from the Contract Price, and the method of determining such value, shall be by unit prices or combinations of unit prices as specified in Schedule 2- Pricing Schedules, or use one of more of the following methods in deciding such value:

- a) by unit prices submitted in the Quote
- b) by unit prices submitted by the Contractor and accepted by the RDCK
- c) by lump sum on the Contractor's estimate and accepted by the RDCK
- d) on a force account basis as specified hereinafter.

### **3.21 Contract Performance Reviews**

From time to time as deemed necessary, the Manager may request that the Contractor participate in a Contract performance review. Documented performance arising from such reviews may be used as basis for alteration of the description of Services or suspension/termination of the Contract.

### **3.22 Rights of Waiver**

A waiver of any breach of or provision of the Contract will not constitute or operate as a waiver or any other breach of any other provision, nor will any failure to enforce any provision herein operate as a waiver of such provisions or of any other provisions.

### **3.23 Duty of Care**

The Contractor acknowledges that the RDCK, in the preparation of the Contract documents, provision of oral or written information to Bidders, review of Quotes or the carrying out of the RDCK's responsibilities under the Contract, does not owe a duty of care to the Contractor and the Contractor waives for itself and its successors, and waives the right to sue the RDCK in tort for any loss, including economic loss, damage, cost or expense arising from or connected with any error, omission or misrepresentation occurring in the preparation of the Contract documents, provision of oral or written information to Bidders, review of Quotes or the carrying out of the RDCK's responsibilities under the Contract.

### **3.24 Severability**

All sections of the Contract are severable one from the other. Should a court of competent jurisdiction find that any one or more sections herein are void the validity of the remaining paragraphs hereof will not be affected.

### **3.25 Compliance with Permits, Laws and Regulations**

The laws and regulations of the place where the Services are supplied shall govern.

The Contractor shall give all required notices and comply with all laws, ordinances, regulations, codes and orders of all authorities having jurisdiction relating to the supply of the Services, to preservation of public health, and to construction safety. If the Contractor observes anything in the Contract Documents to be at variance with the foregoing, they shall promptly notify the RDCK, in writing, and await the RDCK instructions. If the Contractor supplies any Services or performs any work, knowing it to be contrary to such laws, ordinances, regulations, codes or orders, and without giving notice requesting instructions from the RDCK, they shall bear all costs arising there from.

The Contractor shall, at their own expense, procure all permits, licenses and certificates required by law for the supply of the Services.

The Contractor will give all notices and obtain all the licenses and permits required to supply the Services. The Contractor will comply with all laws applicable to the supply of the Services and performance of the Contract.

Any Contract resulting from this Request for Quote will be governed by and will be construed and interpreted in accordance with the laws of the Province of British Columbia.

### **3.26 Security for Supply of Services**

~~Unless otherwise agreed in writing by the RDCK may, in its absolute discretion, the Contractor shall provide to the RDCK security for the performance of its obligations under the Contract in the form of an~~



~~Irrevocable Commercial Letter of Credit in the amount of [%Amount]% of the Contract Price detailed in Schedule 2 of this Request for Quote, which security shall be issued by a financial institution within the RDCK that is acceptable to the RDCK in its absolute discretion and in form and substance approved by the RDCK.~~

### **3.27 Force Majeure**

In the event that either party is rendered wholly or partly unable to perform its obligations hereunder as a result of an event of Force Majeure, then subject to the RDCK's right of termination under Article 3.12- RDCK's Right to Terminate, the Contract, that party will be excused from whatever performance is affected by the event of Force Majeure, to the extent so affected, provided that:

- a) the non-performing party promptly after the occurrence of the event of Force Majeure gives the other party notice describing the particulars of the occurrence;
- b) the suspension of performance is of no greater scope and of no longer duration than is required by the event of Force Majeure;
- c) the non-performing party uses reasonable commercial efforts to remedy its inability to perform; and
- d) when the non-performing party is able to resume performance of its obligations hereunder, that party will give the other party written notice thereof.

## **PART 4 – PAYMENT CLAUSES**

---

### **4 Payment Clauses**

This Part shall be read with and shall form part of the Contract.

#### **4.1 Payment for Services**

This Part sets out the method of measurement and payment to compensate the Contractor for the supply of the Services.

Payment will be made by the RDCK to the Contractor within thirty (30) days of submission by the Contractor of complete service detail for the Services supplied in the previous month during the term of the Contract.

#### **4.2 Goods and Services Tax**

The Contractor shall identify the GST as separate line item on all invoices.

#### **4.3 Payment Withheld or Deducted**

The RDCK may withhold payment on any Progress Payment as may be necessary or prudent to protect itself from loss on account of:

- a) the Contractor is not making satisfactory progress with the supply of the Services;
- b) defective Services which are not remedied;
- c) if applicable, there are claims of lien, or liens (or a lien) filed against any premises of which the Services are supplied or being supplied, or reasonable evidence of the probable filing of such claims of lien or of filing or registration of liens (or a lien) as a result of the failure of the Contractor to make payment properly to Sub-Contractors or for materials, labour, or otherwise;
- d) damages caused to another party by the Contractor;
- e) any other evidence of loss or danger of loss on the part of the RDCK, resulting from of the Contractor's operations.
- f) the RDCK has corrected deficiencies under section 3.11-RDCK's Right to Obtain Services from other suppliers.

#### **4.4 Monies Due to the RDCK**

The Contractor's payment for any commodity value to the RDCK, if any is required by the Contract, will be provided to the RDCK monthly.

All monies payable to the RDCK by the Contractor under any stipulation herein or as provided in section 3.11-RDCK's Right to obtain Services from other suppliers, or section 4.5-Liquidated Damages, may be

retained by the RDCK out of any monies due, or which may become due, from the RDCK to the Contractor under this or any other Contract with the RDCK, or the RDCK may demand payment to the RDCK by the Contractor, or the RDCK may deduct monies from the Irrevocable Commercial Letter of Credit. The RDCK shall have full authority to withhold any amount or estimated amount, if circumstances arise which may indicate the advisability of so doing, though the final sum to be retained may be unascertained.

The RDCK may also, at its discretion, calculate into the monies due to the RDCK, the RDCK's staff time plus a 10% overhead in any event where the RDCK has had to correct deficiencies as per section 3.11-RDCK's Right to Obtain Services from other suppliers.

#### **4.5 Liquidated Damages**

In case the Contractor fails to commence or complete the supply of the Services in accordance with the Contract, and to the satisfaction of the Manager, within the time or times specified, the Contractor shall pay to the RDCK a sum of the annual Contract Price divided by 365 for each and every day that the Services have not been supplied after the times specified; which sum or sums, in view of the difficulty of ascertaining the losses which the RDCK will suffer by reason of delay in the supply of Services, is hereby agreed upon and fixed as a reasonable measure of the RDCK's costs and determined by the parties hereto as the liquidated damages that the RDCK will suffer by reason of said delay and default, and not as a penalty. The RDCK may deduct and retain the amounts of such liquidated damages as per section 4.4-Monies Due to the RDCK.

#### **4.6 Negotiations During Contract Term**

If the RDCK requires changes to the supply of the Services, negotiations for payment to the Contractor for Services not specified herein shall be based on a comparison of similar Services that are specified herein, and as specifically measured by the increase or decrease in process time required, manpower, equipment, etc., each of which will be specifically identified, fully itemized, and at the discretion of the Manager, justified. If similar comparison is not practical, then the item will be specifically negotiated, based on time required, manpower, equipment, etc., each of which will be specifically identified and fully itemized.

# QUOTE FORM

---



## REQUEST FOR QUOTE

### BLOCK STAIRCASE REMEDIATION

**CLOSING DATE & TIME:** 2:00pm PST, September 5, 2024

**COMPANY NAME:** \_\_\_\_\_

**MAILING ADDRESS:** \_\_\_\_\_

**CITY/POSTAL CODE:** \_\_\_\_\_

**EMAIL ADDRESS:** \_\_\_\_\_

**DATED:** \_\_\_\_\_

**TO:** Regional District of Central Kootenay  
Box 590, 202 Lakeside Drive  
Nelson, BC V1L 5R4

The Bidder has carefully examined the Site(s) where the Services will be supplied or used and the Contract Documents for the BLOCK STAIRCASE REMEDIATION.

The undersigned Bidder understands the conditions under which the Services are to be supplied and offers to provide all necessary labour, machinery, tools, equipment, apparatus and other means of construction and do all work and furnish all materials called for by the Contract Documents in the manner prescribed herein and in accordance with the Regional District's requirements, for the rates quoted in Schedule 2- Pricing Schedules and in accordance with the other Schedules of this Quote.

The immediately following schedules, entitled Schedules 1 to 6, shall be read with and form part of this Quote as if embodied herein. The Quote includes all addenda numbers \_\_\_\_\_ to \_\_\_\_\_ inclusive.

The Bidder understands and agrees that:

- a) the proposed rates specified in Schedule 2-Pricing Schedules include all taxes, duties and all other additional charges on any materials, equipment and labour, except the GST which shall be charged separately;
- b) payment will be made only for the supply of Services specified in the Contract. Payment will be made according to the rates proposed in Schedule 2-Pricing Schedules;
- c) The lowest or any Quote will not necessarily be accepted. The RDCK reserves the right in its absolute discretion to: accept the Quote which it deems most advantageous and favorable in the interests of the RDCK; and waive informalities in, or reject any or all Quotes, in each case without giving any notice. In no event will the RDCK be responsible for the costs of preparation or submission of a Quote;

If there is only one compliant Quote received by the Closing Time, the RDCK reserves the right to accept the Quote or cancel the Quote process with no further consideration for the sole Quote. This includes the right to cancel this Request for Quote at any time prior to entering into the Contract with the Contractor. The RDCK reserves the right to cancel at any time before award of the Contract without being obliged to any Bidder – not just where there is only one compliant Quote; and

- d) The RDCK reserves the right, at its sole discretion to waive irregularities and informalities in any Quote and to seek clarification or additional information on any area of any Quote when it is in the best interest of the RDCK to do so. The RDCK, however, may at its sole discretion reject or retain for consideration Quotes which are non-conforming because they do not contain the content or form required by these Instructions to Bidders or because they have not complied with the process for submission set out herein.

*The Bidder agrees as follows:*

- a) If the undersigned is notified in writing of the acceptance of their Quote, it agrees that within fifteen (15) days of the date of the Notice of Award they will enter into an Agreement and execute the Contract for the supply of the Services and guarantees completion of the Contract in accordance with the Contract Documents;
- b) Within fifteen (15) days from the date of the Notice of Award of this Quote, to furnish to the Regional District, the specified insurance and WorkSafe BC clearance letter for the performance of the Contract;
- c) To begin supply of the Services on the date specified in the Notice to Proceed;
- d) Except as expressly and specifically permitted in these Instructions to Bidders, no Bidder shall have any claim for any compensation of any kind whatsoever, as a result of participating in this Request for

Quote, and by submitting a Quote each Bidder shall be deemed to have agreed that it has no claim;  
and

- e) The RDCK reserves the right, at its discretion, to negotiate with any Bidder that the RDCK believes has the most advantageous Quote or with any other Bidder or Bidders concurrently. In no event will the RDCK be required to offer any modified terms to any other Bidder prior to entering into the Contract with the successful Bidder, and the RDCK shall incur no liability to any other Bidder as a result of such negotiations or modifications.

---

Signature of Bidder

**Authorization**

I/we hereby certify that the prices and dates and other information contained in this Quote are correct, and that the signatures below are those of duly authorized officers of our company having the power necessary to make such a Quote.

It is hereby agreed that once the Quotes for the Contract have been opened, this Quote and the offer constituted thereby shall not be revoked before EITHER acceptance thereof by the Regional District OR the expiration of ninety (90) calendar days after the opening of Quotes for the Contract, whichever shall first occur.

**SIGNED, SEALED AND DELIVERED by:**

\_\_\_\_\_  
Name of Bidder (Company)

In the presence of:

\_\_\_\_\_  
Name (printed)

\_\_\_\_\_  
Witness Name (printed)

\_\_\_\_\_  
Authorized Signature

\_\_\_\_\_  
Witness Signature

\_\_\_\_\_  
Address (printed)

\_\_\_\_\_  
Address (printed)

\_\_\_\_\_  
Address (printed)

\_\_\_\_\_  
Address (printed)

\_\_\_\_\_  
Telephone

Fax

\_\_\_\_\_  
Telephone

Fax

DATED at \_\_\_\_\_ this \_\_\_\_\_ day of \_\_\_\_\_, 20\_\_\_\_\_.

## **SCHEDULES**

---

- Schedule 1 - Description of Services
- Schedule 2 - Pricing Schedules
- Schedule 3 - Equipment List
- Schedule 4 - Proposed Sub-Contractors
- Schedule 5 - List of Previous Experience (Contracts)
- Schedule 6 - Schedule of Addenda
- Schedule 7 - Environmental Attributes



# SCHEDULE 1 – DESCRIPTION OF SERVICES

Remediation and replacement of two Allen Block staircases at the Creston & District Community Complex.

**\*MANDATORY SITE VISIT: August 29<sup>th</sup>, 2024 1:00pm PST**

Stairs A

- 90 Inches Wide
- 54 inch rise
- 84 inch run
- Including top stair 7 Steps

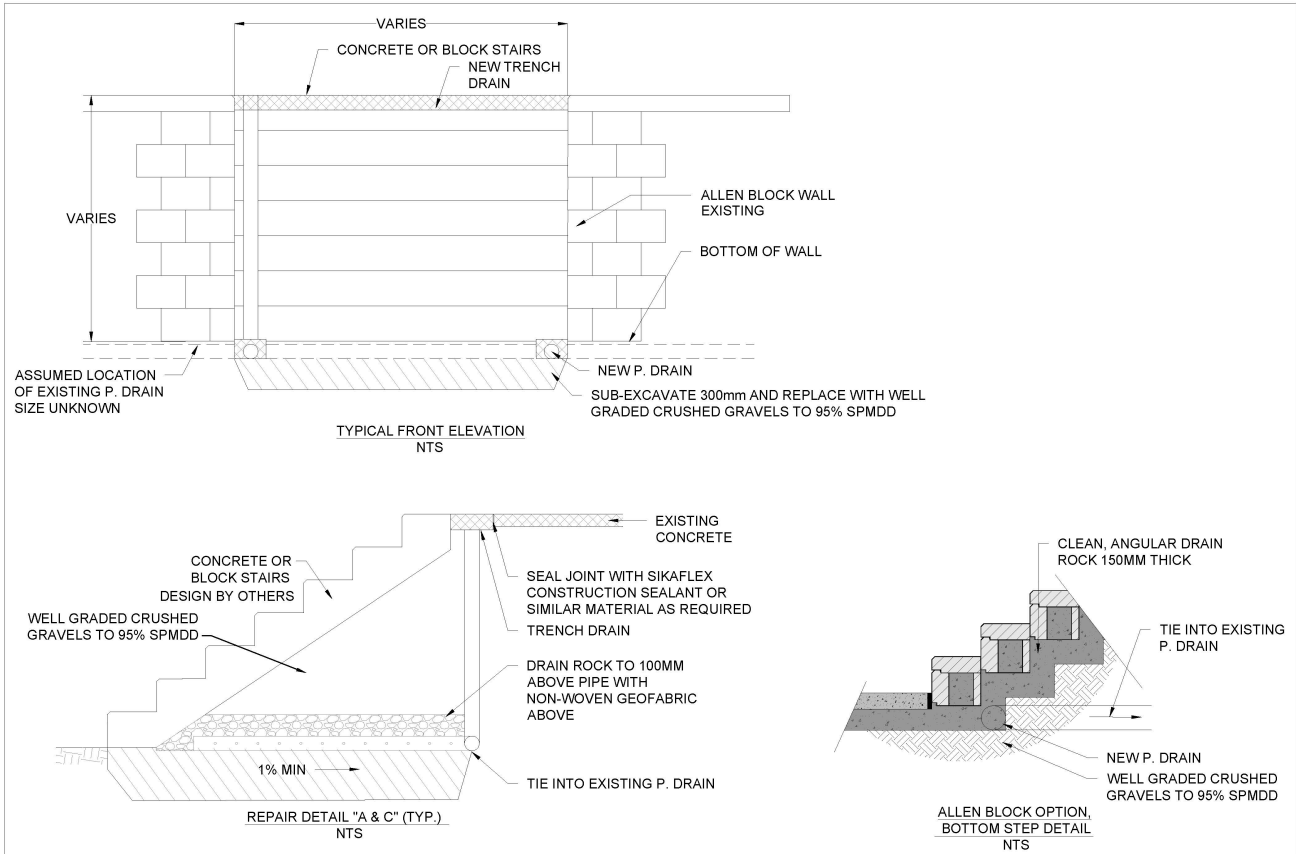

 <b>SNT Engineering Ltd.</b> SUITE 3 - 385 BAKER STREET, NELSON, BC, V1L 4H6 Tel: (250) 354-7683 PERMIT TO PRACTICE# 1001678 www.snteng.ca	<b>Title:</b> CRESTON & DISTRICT COMMUNITY CENTER STAIR REPAIRS	<b>Rev.</b>	<b>Date</b>	<b>Description</b>
	<b>Address:</b> _____	_____	_____	_____
<b>Drawn By:</b> NH	<b>Client:</b> REGIONAL DISTRICT OF CENTRAL KOOTENAY	_____	_____	_____
<b>Designed By:</b> C. STAUFFER, P. ENG.	<b>Proj. No.:</b> RDCK-24-01	<b>Dwg. No.:</b> _____	<b>Scale:</b> NTS	<b>Rev #:</b> 0
<b>Date:</b> 04/15/2024	_____	_____	_____	_____

## **SCHEDULE 2 – PRICING SCHEDULES**

---

This section shall be read with and shall form part of the Contract Form. The Bidder hereby proposes the following prices to provide all materials, supervision, labour, equipment and all else necessary for the proper supply of the Services. Costs of a general nature that do not pertain to any one item shall be pro-rated among all items. No claim for extra payment on the grounds that the Services supplied could not be properly charged to items within the Description of Services will be considered.

[Enter required pricing schedule/tables]

---

Signature of Bidder





## **SCHEDULE 5 – LIST OF PREVIOUS EXPERIENCE (CONTRACTS)**

---

The Bidder shall fill in details below of the most recent contracts they have undertaken with the supply of Services of a nature similar to this proposed Contract.

It is the intention of Regional District of Central Kootenay to use the information given below to assess the experience of the Bidder in the appropriate supply of Services. The RDCK may contact the references given below before awarding the Contract.

### **Bidder's Experience on Projects of a Similar Nature**

Project: \_\_\_\_\_ Value: \_\_\_\_\_

Owner: \_\_\_\_\_ Phone Number: \_\_\_\_\_

Description: \_\_\_\_\_  
\_\_\_\_\_

Project: \_\_\_\_\_ Value: \_\_\_\_\_

Owner: \_\_\_\_\_ Phone Number: \_\_\_\_\_

Description: \_\_\_\_\_  
\_\_\_\_\_

Project: \_\_\_\_\_ Value: \_\_\_\_\_

Owner: \_\_\_\_\_ Phone Number: \_\_\_\_\_

Description: \_\_\_\_\_  
\_\_\_\_\_

\_\_\_\_\_  
Signature of Bidder

**SCHEDULE 6 - ADDENDA**

---

It is herewith acknowledged that the following Addenda have been received and form part of the Quote.

ADDENDUM NO. \_\_\_\_\_ DATED \_\_\_\_\_

ADDENDUM NO. \_\_\_\_\_ DATED \_\_\_\_\_

ADDENDUM NO. \_\_\_\_\_ DATED \_\_\_\_\_

ADDENDUM NO. \_\_\_\_\_ DATED \_\_\_\_\_

ADDENDUM NO. \_\_\_\_\_ DATED \_\_\_\_\_

\_\_\_\_\_  
Signature of Bidder



**APPENDIX A – SITE PLAN**

---



**APPENDIX B – CONTRACT**

---



# Services Agreement

**Contract #:** YYYY-##-DEPT\_CONTRACTOR\_NAME  
**Project:** Add project name  
**GL Code:** Add account and work order OR see Schedule B

THIS AGREEMENT executed and dated for reference the:

day day of month, year  
(Day) (Month) (Year)

## BETWEEN

### REGIONAL DISTRICT OF CENTRAL KOOTENAY

(hereinafter called the **RDCK**)

at the following address:

Box 590, 202 Lakeside Drive

Nelson, BC V1L 5R4

**AND**

### ADD CONTRACTOR NAME

(hereinafter called the **Contractor**)

at the following address:

Add address

City, Province, Postal Code

Agreement Administrator: Add name

Telephone #: Add phone #

Email: Add email

Agreement Administrator: Add name

Telephone: Add phone #

Email: Add email

## 1 FOR GOOD AND VALUABLE CONSIDERATION, THE RECEIPT OF WHICH IS CONFIRMED, THE RDCK AND THE CONTRACTOR AGREE AS FOLLOWS:

- (a) **SERVICES:** The Contractor shall provide the services detailed in **Schedule A** of this Agreement (the **Services**).
- (b) **CHANGES TO SERVICES:** The RDCK and the Contractor acknowledge that it may be necessary to modify the Services, the Project schedule and/or the Budget in order to complete the Project. In the event that the RDCK or the Contractor wishes to make a change or changes to the Services, the Project schedule and/or the Budget it shall notify the other of the proposed change and reason(s) therefore. The party receiving the notification shall review and consider the proposal for change and shall as soon as is reasonably possible and no longer than within five (5) working days, advise in writing the party proposing the change whether it agrees to the change. Where the parties agree to the change, such agreement will form part of this Agreement and be formalized by means of an Agreement Amendment.
- (c) **TERM:** Notwithstanding the date of execution of this Agreement the Contractor shall provide the Services described in Schedule A hereof commencing on **[Start Date]** and ending on **[End Date]** (the **Term**). Agreement may be extended up to two (2) times for a one (1) year term upon mutual agreement.

- (d) **LOCATION:** The location for delivery of the Services shall be [Location].
- (e) **CONTRACT PRICE/RATE:** \$[Amount] (excluding GST) at the rates and on the terms set out in Schedules B and C.
- (f) **BILLING DATE:** Choose Billing Option.
- (g) The following Schedules incorporated into, and form part of this Agreement.  
  
Schedule A: Description of Services  
Schedule B: Contract Payment Terms  
Schedule C: Pricing Schedules  
Schedule D: Personnel & Equipment
- (h) The following terms and conditions are incorporated into, and form part of this Agreement:

## GENERAL CONTRACT CONDITIONS

### 2 The Contractor shall:

- (a) At all times, exercise the standard of care, skill and diligence normally exercised and observed by persons engaged in the performance of services similar to the Services;
- (b) At all times, treat as confidential all information and material supplied to or obtained by the Contractor or subcontractor as a result of this Agreement and not permit the publication, release or disclosure of the same without the prior written consent of the RDCK;
- (c) Not perform any service for any other person, firm or corporation which, in the reasonable opinion of the RDCK, may give rise to a conflict of interest;
- (d) Be an independent Contractor and not the servant, employee or agent of the RDCK;
- (e) Ensure all persons employed by it to perform the Services are competent to perform them, adequately trained, fully instructed and supervised;
- (f) Ensure that all personnel hired by the Contractor to perform the Services will be the employees of the Contractor and not to the RDCK with the Contractor being solely responsible for the arrangement of reliefs and substitutions pay supervision, discipline, employment insurance, workers compensation, leave and all other matters arising out of the relationship of employer and employee;
- (g) Not in any manner whatsoever commit or purport to commit the RDCK to the payment of any money;
- (h) Accept instructions from the RDCK, provided that the Contractor shall not be subject to the control of the RDCK in respect of the manner in which such instructions are carried out;
- (i) Use due care that no person or property is injured and no rights infringed in the performance of the Services, and shall be solely responsible for all losses, damages, costs and expenses in respect to any damage or injury, including death, to persons or property incurred in providing the Services or in any other respect whatsoever.

### ASSIGNMENT

- 3 The Contractor shall not sublet, sell, transfer, assign, or otherwise dispose of the Contract, any portion

thereof, or their right, title, or interest therein, or their obligations there under without written consent of the RDCK which consent may be withheld unreasonably, except for an assignment to a bank of the payments to be received by the Contractor from the RDCK.

## INSURANCE

4 The Contractor must provide the RDCK with a certificate of insurance upon execution of this Agreement in a form acceptable to the Chief Financial Officer of the Regional District and shall, during the Term of this Agreement, take out and maintain the following insurance coverage:

- (a) Automobile Liability (third party) insurance with a minimum limit of \$5,000,000.
- (b) comprehensive commercial general liability insurance against claims for bodily injury, death or property damage arising out of this Agreement or the provision of the Services in the amount of \$ **Amount of Insurance** dollars per occurrence with a **maximum deductible of \$5,000**;

Such insurance will:

- (i) name the Regional District, its elected officials, employees, officers, agents and others as an additional insured;
  - (ii) include the Contractor's Blanket contractual liability;
  - (iii) include a Cross Liability clause;
  - (iv) include occurrence property damage;
  - (v) include personal injury;
  - (vi) include premises & operations insurance;
  - (vii) include a Waiver of Subrogation clause in favor of the RDCK whereby the insurer, upon payment of any claim(s), waives its right to subrogate against the RDCK for any property loss or damage claim(s);
  - (viii) be primary in respect to the operation of the named insured pursuant to the contract with the RDCK. Any insurance or self-insurance maintained by the RDCK will be in excess of such insurance policy (policies) and will not contribute to it;
  - (ix) require the insurer not cancel or materially change the insurance without first giving the RDCK thirty days' prior written notice; provided that if the Contractor does not provide or maintain in force the insurance required by this Agreement, the Contractor agrees that the RDCK may take out the necessary insurance and the Contractor shall pay to the RDCK the amount of the premium immediately on demand.
- (c) professional liability coverage in the amount of \$ **Amount of Insurance** dollars per claim and \$ **Amount of Insurance** dollars aggregate, with a **maximum deductible of \$50,000**;
  - (d) pollution/environmental impairment liability insurance in the amount of \$ **Amount of Insurance** dollars per occurrence and \$ **Amount of Insurance** dollars aggregate, with a **maximum deductible of \$50,000**;

Such insurance will:

- (i) name the Regional District, its elected officials, employees, officers, agents and others as an additional insured;
  - (ii) include the Contractor's Blanket contractual liability;
  - (iii) include a Cross Liability clause;
  - (iv) include a Waiver of Subrogation clause in favor of the RDCK whereby the insurer, upon payment of any claim(s), waives its right to subrogate against the RDCK for any property loss or damage claim(s);
  - (v) be primary in respect to the operation of the named insured pursuant to the contract with the RDCK. Any insurance or self-insurance maintained by the RDCK will be in excess of such insurance policy (policies) and will not contribute to it;
  - (vi) require the insurer not cancel or materially change the insurance without first giving the RDCK thirty days' prior written notice; provided that if the Contractor does not provide or maintain in force the insurance required by this Agreement, the Contractor agrees that the RDCK may take out the necessary insurance and the Contractor shall pay to the RDCK the amount of the premium immediately on demand.
- (e) course of construction/builders risk coverage in the amount of \$ **Amount of Insurance** dollars with a maximum \$10,000 deductible;
- (f) all risk property coverage in an amount sufficient to cover the cost of the contractor's equipment and tools needed for this contract, as well as work product in progress prior to delivery.

Such coverage will:

- (A) Include an Installation Floater

## **INDEMNITY**

- 5** Notwithstanding the provision of any insurance coverage by the RDCK, the Contractor shall indemnify and save harmless the RDCK, its successor(s), assign(s) and authorized representative(s) and each of them from and against losses, claims, damages, actions, and causes of action (collectively referred to as Claims), that the RDCK may sustain, incur, suffer or be put to at any time either before or after the expiration or termination of this Agreement, that arise out of errors, omissions or negligent acts of the Contractor or its subcontractor(s), servant(s), agent(s) or employee(s) under this Agreement, excepting always that this indemnity does not apply to the extent, if any, to which the Claims are caused by errors, omissions or the negligent acts of the RDCK its other contractor(s), assign(s) and authorized representative(s) or any other persons.

## **COMPLIANCE WITH WORKERS COMPENSATION ACT**

- 6** The Contractor shall ensure compliance, on their part and on the part of all of their Sub-Contractors, with the Workers Compensation Act and the Occupational Health and Safety Regulations thereunder.
- 7** Prior to supplying any of the Services in the Contract, the Contractor must provide the RDCK with the Contractor's WorkSafe BC number, and must pay and keep current during the term of the Contract, all assessments required by WorkSafe BC in relation to the supply of the Services or the Contract Price. In any case where pursuant to the provisions of the Workers Compensation Act, an order is given to the

Contractor, or one of their Sub-Contractors in respect to their operations under the Contract to cease operations because of failure to install or adopt safety devices or appliances or methods as directed, or required by the Workers Compensation Act or Regulations there under, or because conditions of immediate danger exist that would be likely to result in injury to any person, and the Contractor is not available or capable of removing the danger to life or equipment resultant from the Contractor's operations then the RDCK may issue a Written Notice to the Contractor and may immediately arrange for the removal of this danger and the Contractor shall be liable for the costs of such arrangements, but such act by the RDCK shall not relieve the Contractor of responsibility for injury, loss of life, or damage which may occur in that situation.

- 8 In the event that the Contractor refuses or fails to comply with an order under the Workers Compensation Act or Regulations thereunder, so that the supply of the Services is stopped, the RDCK may, upon written notice, terminate the Contract and proceed in accordance with Sections 21, 22, 23, 24 - *RDCK's Right to Terminate the Contract*.
- 9 The Contractor shall, during the term of the Contract, maintain Workers Compensation Insurance in order to fully protect both its employees and the RDCK as may be required by law during the term of the Contract and shall on each anniversary date of the Contract, provide the RDCK with proof of payment of claims in good standing with WorkSafe BC by way of a WorkSafe BC Clearance Letter. The Contractor will Be responsible for all fines, levies, penalties and assessments made or imposed under the Worker's Compensation Act and regulations relating in any way to the Services, and indemnify and save harmless fines, levies, penalties and assessments.

#### **HEALTH AND SAFETY**

- 10 The Contractor shall be solely and completely responsible for ensuring safety of all persons and property during the supply of the Services. This requirement shall apply during the Contract period and not be limited to normal working hours.
- 11 The Contractor shall be liable for any and all injury or damage which may occur to persons or to property due to any act, omission, neglect or default of the Contractor, or of their employees, workmen or agents.
- 12 The Contractor shall satisfy the Manager that a safety program has been developed in accordance with the Occupational Health and Safety Regulations, and Safe Work Practices and Procedures of WorkSafe BC and shall incorporate all of the RDCK's operating requirements and restrictions.
- 13 The Contractor shall assign an individual responsible and authorized to supervise and enforce compliance with all safety regulations required in the supply of the Services.

#### **INTENT OF CONTRACT DOCUMENTS**

- 14 The intent of the Contract Documents is that the Contractor shall provide all materials, supervision, labour, equipment and all else necessary for or incidental to the proper supply of the Services described in **Schedule A** and all incidental work to supply the Services. This is not an Agreement of employment. The Contractor is an independent Contractor and nothing herein shall be construed to create a partnership, joint venture or agency and neither party shall be responsible for the debts or obligations of the other.

#### **RDCK REPRESENTATIVE'S AUTHORITY**

- 15 The RDCK Representative will observe the supply of the Services in progress on behalf of the RDCK. The RDCK Representative will have the authority to stop the supply of the Services whenever such stoppage may be necessary, in their opinion, to ensure the proper supply of the Services in accordance with the

provisions of the Contract.

## **NOTICE TO PROCEED**

- 16** Following the execution of the Contract by the Contractor and the provisions of the required Irrevocable Commercial Letter of Credit and insurance policies, a written Notice to Proceed with the supply of the Services will be given to the Contractor by the RDCK. The Contractor shall supply the Services at the time specified in the Contract or, if applicable, begin supplying the Services on the first day of the Term and shall proceed with the supply of the Services regularly and without interruption thereafter throughout the Term, unless otherwise directed in writing by the Manager or RDCK.

## **RDCK'S RIGHT TO OBTAIN SERVICES FROM OTHER SUPPLIERS**

- 17** If the Contractor should refuse or fail to supply adequate workmanship, products, or machinery and equipment for the scheduled supply of the Services, or neglects to supply the Services properly, or fails to perform any of the provisions of the Contract, then the RDCK, without prejudice to any of its other rights under the Contract, may notify the Contractor in writing, that the Contractor is in default of their contractual obligations, and instruct him to correct the default within forty-eight (48) hours.
- 18** If the correction of the default cannot be completed within forty-eight (48) hours as specified, the Contractor shall be considered to be in compliance with the RDCK's instruction if it commences the correction of the default within the specified time, and in addition provides the RDCK with a schedule that is acceptable to the RDCK in its sole discretion for such correction and completes the corrections in accordance with such schedule.
- 19** If the Contractor fails to comply with the provisions of this section the RDCK may, without prejudice to any other right or remedy they may have, obtain the supply of Services from another supplier and may deduct the cost thereof from the payment then or thereafter due the Contractor, or may without notice to the Contractor deduct the cost from the amount secured under the Irrevocable Commercial Letter of Credit.

## **RDCK'S RIGHT TO TERMINATE THE CONTRACT**

- 20** If the Contractor should:
- (a) be adjudged bankrupt, or make a general assignment for the benefit of creditors, or if a receiver is appointed on account of their insolvency, or
  - (b) fail to make sufficient payments due to their Sub-Contractors, or suppliers, or
  - (c) disregard laws or regulations that apply to the supply of the Services, or the RDCK's instructions, or
  - (d) abandon the supply of the Services, or
  - (e) otherwise violate the conditions of the Contract, the RDCK shall, by written notice, instruct the Contractor to correct the default within forty-eight (48) hours.
- 21** If the default is not corrected within forty-eight (48 hours), then the RDCK may, without prejudice to any other right or remedy they may have, terminate the Contract. If notice has been given to the Contractor under Sections 17, 18 and 19 of the contract - *RDCK's Right to Obtain Services from Other Suppliers*, then a further notice and time to correct the default is not required and that in addition to correcting the default RDCK may without further notice proceed to terminate the Contract.

- 22** If the RDCK terminates the Contract under the conditions set out above, the RDCK shall be entitled to:
- (a) obtain the supply of the Services by whatever method is deemed expedient but without undue delay or expense;
  - (b) withhold any further payments to the Contractor until the supply of the Services is finished;
  - (c) upon completion of the supply of the Services, determine the full cost of obtaining the supply of the Services including compensation to the RDCK for this additional service and a reasonable allowance to cover the costs of any corrections required under the guarantee, and charge the Contractor the amount by which the full cost exceeds the unpaid balance of the Contract Price; or if such cost of obtaining the supply of the Services is less than the unpaid balance of the Contract Price, pay the Contractor the difference; or if such cost of finishing the supply of the Services is greater than the unpaid balance deduct the difference from the Irrevocable Commercial Letter of Credit.
- 23** It is also understood and agreed by and between the parties to the Contract, that in the event of a strike or lockout of the employees of the RDCK taking place during the term of the Contract, during which the supply of the Services may be interrupted or blocked, that the provisions of the Contract requiring payment by the RDCK to the Contractor shall be renegotiated on the basis of the Contractor's actual proven costs for the period.
- 24** It is also understood and agreed by and between the parties to the Contract, that in the event of a strike or lockout of the employees of the Contractor taking place during the term of the Contract, during which the supply of the Services may be interrupted or blocked, that the RDCK shall at its option and without penalty or further payment to the Contractor, have the right to unilaterally terminate the Contract, and to remove the Contractor, their employees and equipment from the Site.

#### **CONTRACTOR'S RIGHT TO STOP SUPPLY OF SERVICES OR TERMINATE THE CONTRACT**

- 25** If the supply of the Services should be stopped or otherwise delayed for a period of ninety (90) days or more under an order of any court, or other public authority, and provided that such order was not issued as the result of any act or fault of the Contractor or of anyone directly or indirectly employed by him, the Contractor may, without prejudice to any other right or remedy they may have, by giving the RDCK written notice, hold the RDCK in default.
- 26** The Contractor may notify the RDCK in writing that the RDCK is in default of its contractual obligations if the RDCK, subject to requirements of these Contract General Conditions fails to pay to the Contractor when due, any amount due and owing to the Contractor under the Contract. Such written notice shall advise the RDCK that if such default is not corrected within thirty (30) calendar days from the receipt of the written notice the Contractor may, without prejudice to any other right or remedy it may have, stop the supply of the Services and terminate the Contract.
- 27** If the Contractor terminates the Contract under the conditions set out above, they shall be paid for all Services supplied and for any loss sustained upon products and construction machinery and equipment, with reasonable profit up to the time that the Contract is terminated. If the Contractor terminates the Contract this is their sole remedy and the RDCK will not be liable for any additional costs or for any loss of profit following termination.

#### **SUB-CONTRACTORS**

- 28** The Contractor agrees to preserve and protect the rights of the RDCK with respect to any supply of Services or work performed under the Contract and shall:



- (a) enter into Contracts or written Agreements with the Sub-Contractors requiring them to supply Services and perform work in accordance with and subject to the terms and conditions of the Contract Documents; and
- (b) be as fully responsible to the RDCK for acts and omissions of the Sub-Contractors and of persons directly or indirectly employed by them as for acts and omissions of persons directly employed by the Contractor.

- 29 The Contractor therefore shall incorporate all terms and conditions of the Contract General Conditions into all Sub-Contract Agreements they enter into with their Sub-Contractors, insofar as they are applicable.
- 30 The Contractor agrees to employ only those Sub-Contractors proposed by him in writing in Schedule E-Proposed Sub-Contractors, and accepted by the RDCK for such portions of the supply of the Services as may be designated.
- 31 The RDCK may, for reasonable cause, object to the use of a proposed Sub-Contractor and require the Contractor to employ another that is acceptable to the RDCK. Under these circumstances, the RDCK will advise the Contractor, in writing, of its objection to a Sub-Contractor. The Contractor shall provide the names of alternate Sub-Contractors for that part of the supply of the Services, each of whom must be acceptable to the RDCK. The Contractor and the RDCK will then agree as to which new Sub-Contractor shall be used.
- 32 Nothing contained in the Contract General Conditions shall create any contractual obligation between any Sub-Contractor and the RDCK.
- 33 Sub-Contractors shall not further sub-contract any portion of the supply of the Services that is the subject of their sub-contract without prior written approval of the RDCK, which may not be withheld unreasonably.

#### **PRIVATE LAND**

- 34 If applicable, it shall be the Contractor's responsibility to ascertain the boundaries within which the supply of Services must be confined. The Contractor shall not enter upon lands other than those provided by the RDCK for any purpose without obtaining prior written permission of the land-owners and occupiers. A copy of the written permission is to be provided to the RDCK prior to entry upon private lands.
- 35 The Contractor shall not enter upon lands owned by others on which the RDCK has easements or rights-of-entry without having received the prior written authorization of the RDCK for such entry. It shall be the Contractor's responsibility to ascertain from the RDCK the conditions on which easements of rights-of-entry have been granted on private lands and to abide by these conditions throughout.

#### **DISPUTE RESOLUTION**

- 36 All claims, disputes or issues in dispute between the RDCK and the Contractor shall be decided by mediation or arbitration if the parties agree, or failing agreement, in a court of competent jurisdiction within the Province of British Columbia. All procedures for the resolution of disputes arising in relation to the Contract shall be governed by the laws of British Columbia, Canada.
- 37 In the event that the parties agree to arbitration, the arbitration shall be governed by the rules of the British Columbia International Arbitration Centre, except that the Arbitrator(s) shall be agreed upon by the parties, and failing agreement by the parties, shall be appointed by a court of competent jurisdiction within the Province of British Columbia, Canada.

- 38 Arbitration will take place in the Southern Interior of British Columbia and be governed by the laws of the Province of British Columbia, Canada.

## TAXES AND DUTIES

- 39 The Contractor shall pay all government sales taxes, customs duties and excise taxes with respect to the Contract including but not limited to any GST or PST. The Contractor is required to identify any applicable tax separately on all invoices and the RDCK is liable to pay this amount to the Contractor. Where an exemption of government sales taxes, custom duties or excise taxes is applicable to the Contract by way of the Contractor filing claims for, or cooperating fully with the RDCK and the proper authorities in seeking to obtain such refunds, the procedure shall be established in a Supplementary Condition.

## STAFF RESOURCES AND MANAGEMENT

- 40 The Contractor shall, at all times during the term of the Contract, have a Supervisor charged with the responsibility of supervising the operations of the Contractor and shall maintain a local office at all times and a telephone staffed during all working hours throughout the duration of the Contract.
- 41 The Contractor shall employ properly qualified and trained equipment operators, labourers and supervisory staff for the operation of the Contract and shall make available a sufficient number of staff to complete the supply of the Services. Failure or delay in the performance of the Contract due to the Contractor's inability to obtain personnel of the number and skill required shall constitute a default of the Contract.
- 42 The Contractor shall ensure that no person will be discriminated against because of race, colour, sex, age, religion or origin. Wages and hours of labour employed shall be in accordance with all applicable federal, provincial and municipal enactments. The Contractor shall, at all times, enforce discipline and good order among their employees, and shall not employ on the Site any unfit person or anyone not skilled in the work assigned to them. Any persons employed on the Site, who become intoxicated, intemperate, disorderly, incompetent or willfully negligent, shall, at the written request of the RDCK Representative, be removed from the Site and shall not be employed again in any portion of the supply of the Services without the approval of the RDCK Representative.

## EMERGENCY CALL OUTS

- 43 Before commencement of the Contract, the Contractor shall provide to the Owner with a list of at least three names and telephone numbers of the Contractor's representatives who can be called outside normal working hours to act for the Contractor for emergency "call outs" in connection with Work under the Contract. Names are to be listed in **Schedule D – Personnel and Equipment**. At least one person on the list shall be available at all times outside of normal working hours. The Contractor shall issue an updated list whenever a change in call out personnel or phone numbers is made.

## RIGHT TO AUDIT

- 44 Upon reasonable notice the Contractor and/or any Sub-Contractors shall provide the RDCK and its internal auditors, external auditors, its regulators and such other entities/persons as the RDCK may designate, with unrestricted access at reasonable times to the data and records relating to the supply of the Services, including but not limited to the Contractor's marketing and sale of the recyclable material, the amounts charged to the RDCK by the Contractor, and the amounts of any commodity value rebates that are payable. Such access will be provided in order to verify the accuracy of charges and invoices for the Services supplied.

## CHANGE IN THE SERVICES

- 45 The RDCK, without invalidating the Contract, may make changes by altering, adding to, or deducting from the Services. The Contractor shall proceed with the supply of the Services as changed and the Services shall be supplied under the provisions of the Contract. No changes shall be undertaken by the Contractor, without written order from the RDCK, except in an emergency endangering life or property, and no claims for additional compensation shall be valid unless the change in writing was so ordered.
- 46 If such changes affect the requirements of the Contract, they will be so specified at the time of ordering the changes. The value of the addition or deduction from the Contract Price, and the method of determining such value, shall be by unit prices or combinations of unit prices as specified in **Schedule C - Pricing Schedules**, or use one of more of the following methods in deciding such value:
- by unit prices submitted in the Proposal
  - by unit prices submitted by the Contractor and accepted by the RDCK
  - by lump sum on the Contractor's estimate and accepted by the RDCK
  - on a force account basis as specified hereinafter.

## INSPECTION OF THE WORK

- 47 The Owner's Representative will inspect the Work during the period of operation and will observe the Work in progress on behalf of the Regional District. The Owner's Representative will have the authority to stop the Work whenever such stoppage may be necessary, in his opinion, to ensure the proper execution of the Work in accordance with the provisions of the Contract Agreement.
- 48 The Regional District and its representatives shall at all times have access to the Work whenever it is in preparation or progress and the Contractor shall provide proper facilities for such access and for inspection.
- 49 If the specifications, the Regional District's instructions, laws, ordinances, or any public authority requires any Work to be specially tested or approved, the Contractor shall give the Owner's Representative timely notice of his readiness for inspection, and if the inspection is by an authority other than the Regional District, the date fixed for such inspection.
- 50 If any Work should be covered up without approval or consent of the Regional District it must, if required by the Regional District, be uncovered for examination at the Contractor's expense.
- 51 Examination of questioned Work may be ordered by the District and if so ordered the Work shall be uncovered by the Contractor. If such Work is found not to be in accordance with the Contract Documents through the fault of the Contractor, the Contractor shall pay the cost of examination and replacement of the Work. If such Work is found to be in accordance with the Contract Documents, the Regional District shall pay these costs.

## CONTRACT PERFORMANCE REVIEWS

- 52 From time to time as deemed necessary, the Manager may request that the Contractor participate in a Contract performance review. Documented performance arising from such reviews may be used as basis for alteration of the description of Services or suspension/termination of the Contract.

## RIGHTS OF WAIVER

- 53 A waiver of any breach of or provision of the Contract will not constitute or operate as a waiver or any

other breach of any other provision, nor will any failure to enforce any provision herein operate as a waiver of such provisions or of any other provisions.

## **DUTY OF CARE**

**54** The Contractor acknowledges that the RDCK, in the preparation of the Contract documents, provision of oral or written information to Proponents, review of Proposals or the carrying out of the RDCK's responsibilities under the Contract, does not owe a duty of care to the Contractor and the Contractor waives for itself and its successors, and waives the right to sue the RDCK in tort for any loss, including economic loss, damage, cost or expense arising from or connected with any error, omission or misrepresentation occurring in the preparation of the Contract documents, provision of oral or written information to Proponents, review of Proposals or the carrying out of the RDCK's responsibilities under the Contract.

## **SEVERABILITY**

**55** All sections of the Contract are severable one from the other. Should a court of competent jurisdiction find that any one or more sections herein are void the validity of the remaining paragraphs hereof will not be affected.

## **COMPLIANCE WITH PERMITS, LAWS AND REGULATIONS**

**56** The laws and regulations of the place where the Services are supplied shall govern.

**57** The Contractor shall give all required notices and comply with all laws, ordinances, regulations, codes and orders of all authorities having jurisdiction relating to the supply of the Services, to preservation of public health, and to construction safety. If the Contractor observes anything in the Contract Documents to be at variance with the foregoing, they shall promptly notify the RDCK, in writing, and await the RDCK instructions. If the Contractor supplies any Services or performs any work, knowing it to be contrary to such laws, ordinances, regulations, codes or orders, and without giving notice requesting instructions from the RDCK, they shall bear all costs arising there from.

**58** The Contractor shall, at their own expense, procure all permits, licenses and certificates required by law for the supply of the Services.

**59** The Contractor will give all notices and obtain all the licenses and permits required to supply the Services. The Contractor will comply with all laws applicable to the supply of the Services and performance of the Contract.

**60** This Agreement shall be governed by and will be construed and interpreted in accordance with the laws of the Province of British Columbia.

## **SECURITY FOR SUPPLY OF SERVICES**

**61** Unless otherwise agreed in writing by the RDCK may, in its absolute discretion, the Contractor shall provide to the RDCK security for the performance of its obligations under the Contract in the form of an Irrevocable Commercial Letter of Credit in the amount of **10%** of the Total Annual Contract Price detailed in **Schedule C: Pricing Schedules**, which security shall be issued by a financial institution within the RDCK that is acceptable to the RDCK in its absolute discretion and in form and substance approved by the RDCK.

## **FORCE MAJEURE**

**62** In the event that either party is rendered wholly or partly unable to perform its obligations hereunder as a

result of an event of Force Majeure, then subject to the RDCK's right of termination under Sections 21, 22, 23, 24 - *RDCK's Right to Terminate the Contract.*, that party will be excused from whatever performance is affected by the event of Force Majeure, to the extent so affected, provided that:

- (a) the non-performing party promptly after the occurrence of the event of Force Majeure gives the other party notice describing the particulars of the occurrence;
- (b) the suspension of performance is of no greater scope and of no longer duration than is required by the event of Force Majeure;
- (c) the non-performing party uses reasonable commercial efforts to remedy its inability to perform; and
- (d) when the non-performing party is able to resume performance of its obligations hereunder, that party will give the other party written notice thereof.

## **GENERAL**

- 63** Time shall be of the essence of this Agreement.
- 64** Any notice required to be given hereunder shall be delivered or mailed by prepaid certified or registered mail to the addresses above (or at such other address as either party may from time to time designate by notice in writing to the other), and any such notice shall be deemed to be received 72 hours after mailing.
- 65** This Agreement shall be binding upon the parties and their respective successors, heirs and permitted assigns.
- 66** A waiver of any provision or breach by the Contractor of any provision of this Agreement shall be effective only if it is in writing and signed by the RDCK.
- 67** A waiver under Section 66 shall not be deemed to be a waiver of any subsequent breach of the same or any other provision of this Agreement.
- 68** Everything produced, received or acquired (the "Material") by the Contractor or subcontractor as a result of this Agreement, including any property provided by the RDCK to the Contractor or subcontractor, shall:
  - (a) be the exclusive property of the RDCK; and
  - (b) be delivered by the Contractor to the RDCK immediately upon the RDCK giving notice of such request to the Contractor.
- 69** The copyright in the Material belongs to the RDCK.
- 70** The RDCK may, at its discretion, notify the Contractor that the terms, amounts and types of insurance required to be obtained by the Contractor hereunder be changed.
- 71** Where the Contractor is a corporation, it does hereby covenant that the signatory hereto has been duly authorized by the requisite proceedings to enter into and execute this Agreement on behalf of the Contractor.
- 72** Where the Contractor is a partnership, all partners are to execute this Agreement.
- 73** Sections 2 c), d), Sections 5 and 69 of this Agreement will, notwithstanding the expiration or earlier termination of the Term, remain and continue in full force and effect.

**74** Except as expressly set out in this Agreement, nothing herein shall prejudice or affect the rights and powers of the RDCK in the exercise of its powers, duties or functions under the Community Charter or the Local Government Act or any of its bylaws, all of which may be fully and effectively exercised as if this Agreement had not been executed and delivered.

IN WITNESS WHEREOF the parties hereto have duly executed this Agreement as of the day and year first above written.

REGIONAL DISTRICT OF CENTRAL KOOTENAY	ADD CONTRACTOR NAME
<hr/> (Signature of Authorized Signatory)	<hr/> (Signature of Authorized Signatory)
<hr/> (Name and Title of Authorized Signatory)	<hr/> (Name and Title of Authorized Signatory)
<hr/> (Signature of Authorized Signatory)	<hr/> (Signature of Authorized Signatory)
<hr/> (Name and Title of Authorized Signatory)	<hr/> (Name and Title of Authorized Signatory)

**SCHEDULE A: DESCRIPTION OF SERVICES**

**INSERT SCOPE OF WORK FROM RFP**

## SCHEDULE B: CONTRACT PAYMENT TERMS

### BUDGET

- 1 Total budget shall not exceed \$[Amount] (excluding GST) over the **three year** contract term unless otherwise negotiated in advance of the work completed. Costs shall be based on amounts in **Schedule C** (excluding GST).

### INVOICING

- 2 Invoices to be submitted **Choose Billing Option**.
- 3 The following contract number and GL code(s) **must** be quoted on the invoice(s):  
Contract Number: **YYYY-##-DEPT\_CONTRACTOR\_NAME**  
GL Code: **ACCOUNT # & WORK ORDER #**
- 4 Invoices must be emailed to [ap@rdck.bc.ca](mailto:ap@rdck.bc.ca), with the contract administrator identified on the first page of this contract in cc.
- 5 Invoices to be paid on net 30 day term.
- 6 The Contractor's GST number must be included on invoices where GST is applicable, in which case, GST shall also be listed as a separate line item.
- 7 The Contractor's name on the invoice must match the name identified in the first page of this contract.
- 8 Invoices for work performed in the calendar year shall be emailed to [ap@rdck.bc.ca](mailto:ap@rdck.bc.ca) no later than January 15th of the following year.

### PAYMENT WITHHELD OR DEDUCTED

- 9 The RDCK may withhold payment on any Progress Payment as may be necessary or prudent to protect itself from loss on account of:
  - (a) the Contractor is not making satisfactory progress with the supply of the Services;
  - (b) defective Services which are not remedied;
  - (c) if applicable, there are claims of lien, or liens (or a lien) filed against any premises of which the Services are supplied or being supplied, or reasonable evidence of the probable filing of such claims of lien or of filing or registration of liens (or a lien) as a result of the failure of the Contractor to make payment properly to Sub-Contractors or for materials, labour, or otherwise;
  - (d) damages caused to another party by the Contractor;
  - (e) any other evidence of loss or danger of loss on the part of the RDCK, resulting from of the Contractor's operations.
  - (f) the RDCK has corrected deficiencies under Sections 17, 18 and 19 of the contract - *RDCK's Right to Obtain Services from Other Suppliers*.



## MONIES DUE TO THE RDCK

- 10 The Contractor's payment for any commodity value to the RDCK, if any is required by the Contract, will be provided to the RDCK monthly.
- 11 All monies payable to the RDCK by the Contractor under any stipulation herein or as provided in Sections 17, 18 and 19 of the contract - *RDCK's Right to Obtain Services from Other Suppliers*, or Section 6 of this Schedule - *Liquidated Damages*, may be retained by the RDCK out of any monies due, or which may become due, from the RDCK to the Contractor under this or any other Contract with the RDCK, or the RDCK may demand payment to the RDCK by the Contractor, or the RDCK may deduct monies from the Irrevocable Commercial Letter of Credit. The RDCK shall have full authority to withhold any amount or estimated amount, if circumstances arise which may indicate the advisability of so doing, though the final sum to be retained may be unascertained.
- 12 The RDCK may also, at its discretion, calculate into the monies due to the RDCK, the RDCK's staff time plus a 10% overhead in any event where the RDCK has had to correct deficiencies as per Sections 17, 18 and 19 of the contract - *RDCK's Right to Obtain Services from Other Suppliers*.

## LIQUIDATED DAMAGES

- 13 In case the Contractor fails to commence or complete the supply of the Services in accordance with the Contract, and to the satisfaction of the Manager, within the time or times specified, the Contractor shall pay to the RDCK a sum of the annual Contract Price divided by 365 for each and every day that the Services have not been supplied after the times specified; which sum or sums, in view of the difficulty of ascertaining the losses which the RDCK will suffer by reason of delay in the supply of Services, is hereby agreed upon and fixed as a reasonable measure of the RDCK's costs and determined by the parties hereto as the liquidated damages that the RDCK will suffer by reason of said delay and default, and not as a penalty. The RDCK may deduct and retain the amounts of such liquidated damages as per Sections 10,11 and 12 of this Schedule - *Monies Due to the RDCK*.

## NEGOTIATIONS DURING CONTRACT TERM

- 14 If the RDCK requires changes to the supply of the Services, negotiations for payment to the Contractor for Services not specified herein shall be based on a comparison of similar Services that are specified herein, and as specifically measured by the increase or decrease in process time required, manpower, equipment, etc., each of which will be specifically identified, fully itemized, and at the discretion of the Manager, justified. If similar comparison is not practical, then the item will be specifically negotiated, based on time required, manpower, equipment, etc., each of which will be specifically identified and fully itemized.

## ANNUAL ADJUSTMENTS

- 15 The price as presented in Schedule C: *Pricing Schedules* shall be adjusted annually on the anniversary date of the Contract according to the following formula:

*Cumulative Annual Contract Price x Percentage Change of the Statistics Canada Average Consumer Price Index for British Columbia for the Transportation Industry of the 12 months prior to the month immediately preceding the date for which the fee rate is being adjusted.*

- 16 On the anniversary of the Contract it is the responsibility of the Contractor to engage with the RDCK to determine any adjustments. Supporting calculations and documentation shall be available for both parties to review and approve. The Contractor shall adjust invoices accordingly as soon as possible.
- 17 The RDCK will, at its absolute discretion, reserve the right to review and adjust the formula annually. The

tables referenced by Statistics Canada will be the most up to date and relevant tables available at the time of the adjustment. No other adjustment to the Contract Price will be made during the term of the Contract.

**SCHEDULE C: PRICING SCHEDULES**

**INSERT SCHEDULE PROVIDED BY PROPONENT**

**SCHEDULE D: PERSONNEL & EQUIPMENT**

**INSERT SCHEDULE PROVIDED BY PROPONENT**

**SCHEDULE E - SUBCONTRACTORS**

**INSERT SUBCONTRACTOR SCHEDULE PROVIDED BY PROPONENT**

<b>Project:</b>	<b>CDCC – Block Staircase Assessment</b>
<b>Client:</b>	Regional District of Central Kootenay
<b>Contractor Representative:</b>	Joseph Feit – Facility Maintenance Working Foreman / Chief Engineer
<b>Contract #:</b>	2024-063-VOM_CDCC-SNT_ENGINEERING
<b>Inspection by:</b>	Carson Stauffer, P.Eng
<b>Site Conditions:</b>	Clear, Sunny
<b>Weather:</b>	8°C
<b>Field Review Date:</b>	March 25 <sup>th</sup> , 2024

**BACKGROUND:**

SNT Engineering was engaged by the RDCK to assess the ongoing failure of a set of stairs at the Creston & District Community Complex. A background review of some general construction photos and architectural drawings were the extent of the construction documents able to be provided. Carson Stauffer, P.Eng., completed a field review on March 25<sup>th</sup>, 2024 meeting RDCK representative Joseph Feit on site to discuss the problems.

- Stairs “A” and “B” slated for replacement this year, Stair “C” will continue to be monitored and likely replaced next year.
- Construction of stairs and wall was completed in 2010.
- Perimeter drain installed at inside bottom of wall (Record photos) with angular drain rock.
- Stairs (A) closed last year indefinitely due to settlement of the topmost steps and tripping hazard to users.

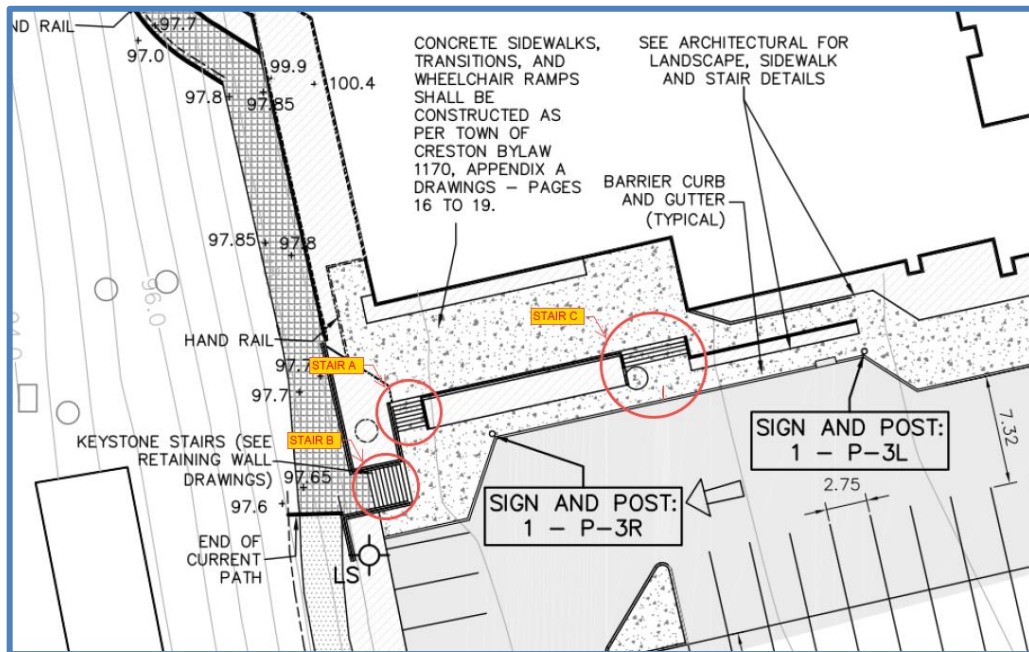

Figure 1 - Excerpt from "2010-06-04-Creston\_Civil\_Surface\_Works-Drawing"

## REFERENCES:

---

- Architectural Drawings – VDA-April 2008
  - 2010-03-10-Creston\_Aquatic\_Centre\_Architectural\_Record\_Drawings
- Civil Surface Works IFT Drawings – McElhanney
  - 2010-06-04-Creston\_Civil\_Surface\_Works-Drawing

## COMMENTS:

---

- Existing materials below stairs A were inspected, difficult to determine the quality of compaction achieved below the steps during construction. Material is a coarse granular material with an acceptable number of fines.
- Failure of Stairs “A” is expected to do with poor drainage below the stairs and the direct flow of water off of the concrete pad to the stairs. A combination of heavy cyclical loading while the bearing materials were saturated caused settlement.
  - Settlement is more prominent at the center of the steps, higher traffic and further from the support of the adjacent wall.
  - Similar settlement pattern at stairs B and C, however not a hazard to the public yet.
- Drainage paths reviewed.
  - Concrete sidewalk between stairs C and A directs water to the base of stairs A. This is expected to have contributed to the structure failure.
  - The upper concrete pad directs water toward the top of stairs A and C, saturating the base material.
  - Stairs B have no water infiltrating from the top of the stairs.
- Another set of Allen Block stairs were inspected at the back of the building, these appeared to have no settlement. Likely due to the very low traffic as it accesses an emergency exit/small rear parking lot.
- The Allen Block walls in the immediate area show no signs of settlement or leaning. The drain rock behind the wall and perimeter drain at the base appears to be functioning well.
- Stairs C have not failed as prominently as stairs A or B, likely due to the shallower fill below them and less water directed towards them.

## RECOMMENDATIONS:

---

The following recommendations are based off field observations and construction best practices. Due to the limitation of background information and covered foundation materials they may not account for all conditions encountered during construction. Following these recommendations should result in a stable new structure with effective drainage to prevent future settlement. Cast-in-place concrete is the preferred material considering longevity and user safety.

## Stairs “A”

- Keep Left (west) side Allen Block wall intact, this is a structural component of the wall that continues.
  - Optionally rebuild the Right side of the steps with Allen block to retain the aesthetic feature, following original installation procedure for Allen blocks (not in this scope)
- Install a trench drain across the interface between existing concrete and top of stairs, tie this drain directly into the existing perimeter drain.
- Sub-excavate minimum 300mm below bottom of existing stairs and replace with well graded crushed gravels and compact to 95% SPMDD.
- Install perimeter drain at bottom elevation of the steps on left and right sides and tie-into existing perimeter drain.
- Cut back concrete up to 1m away on east side of existing Allen Block wall. Regrade away from wall/stairs towards the drain to the south.
- No backfill materials should be re-used, replace any fill with a coarse well draining gravel and angular drain rock as required.
- Follow the same practices for Allen Block replacement or concrete installation. If using Allen blocks replace like-for-like following original block layout plan, refer to the Allen Block Website for best practices for stair and wall construction.

## Stairs “B”

- Keep Left (west) side Allen Block wall intact, this is a structural component of the wall that continues to the North.
- Sub-excavate minimum 300mm below bottom of existing stairs and replace with well graded crushed gravels and compact to 95% SPMDD.
- Install perimeter drain at bottom elevation of the steps on left and right sides and tie-into existing perimeter drain.
- No backfill materials should be re-used, replace any fill with a coarse well draining gravel and angular drain rock as required.
- If replacing with concrete, seal joint on the south side between existing concrete and new steps with Paraseal or similar product following the manufacturers specifications.
- Follow the same practices for Allen Block replacement or concrete installation. If using Allen blocks replace like-for-like following original block layout plan, refer to the Allen Block Website for best practices for stair and wall construction.

Prepared by:





Les Thiessen, P.Eng.

SNT Engineering Ltd. Permit to Practice #1001678

PHOTO LOG – March 25<sup>th</sup>, 2024

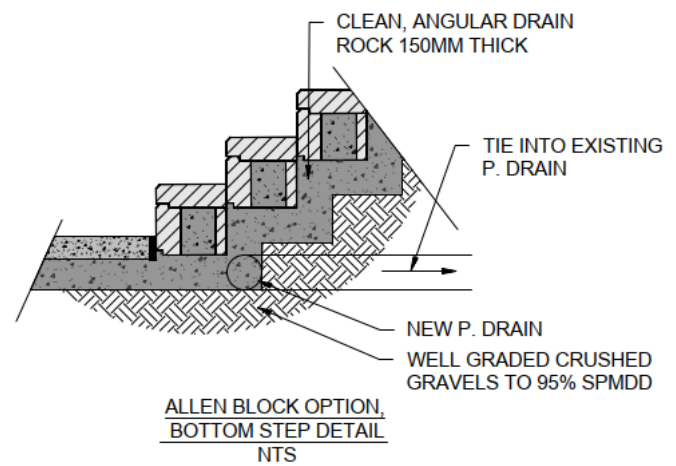
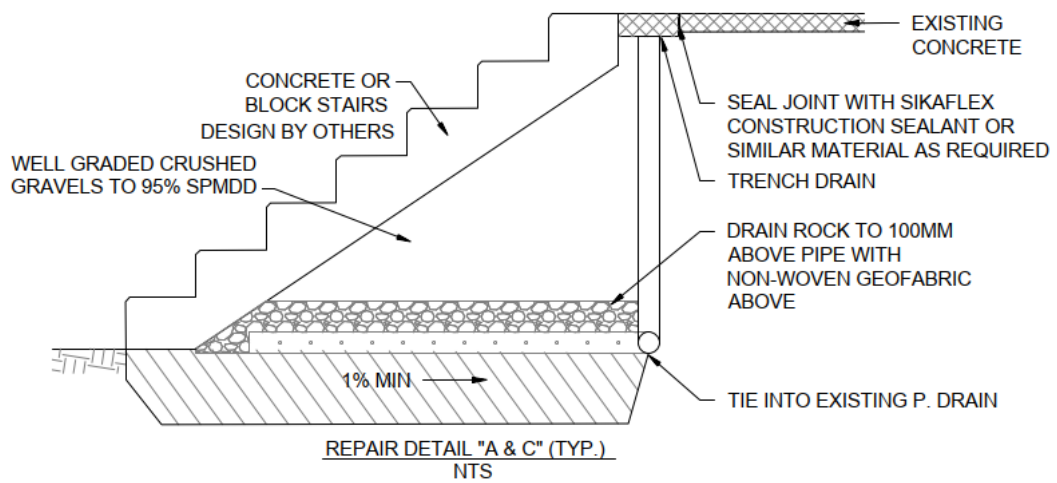
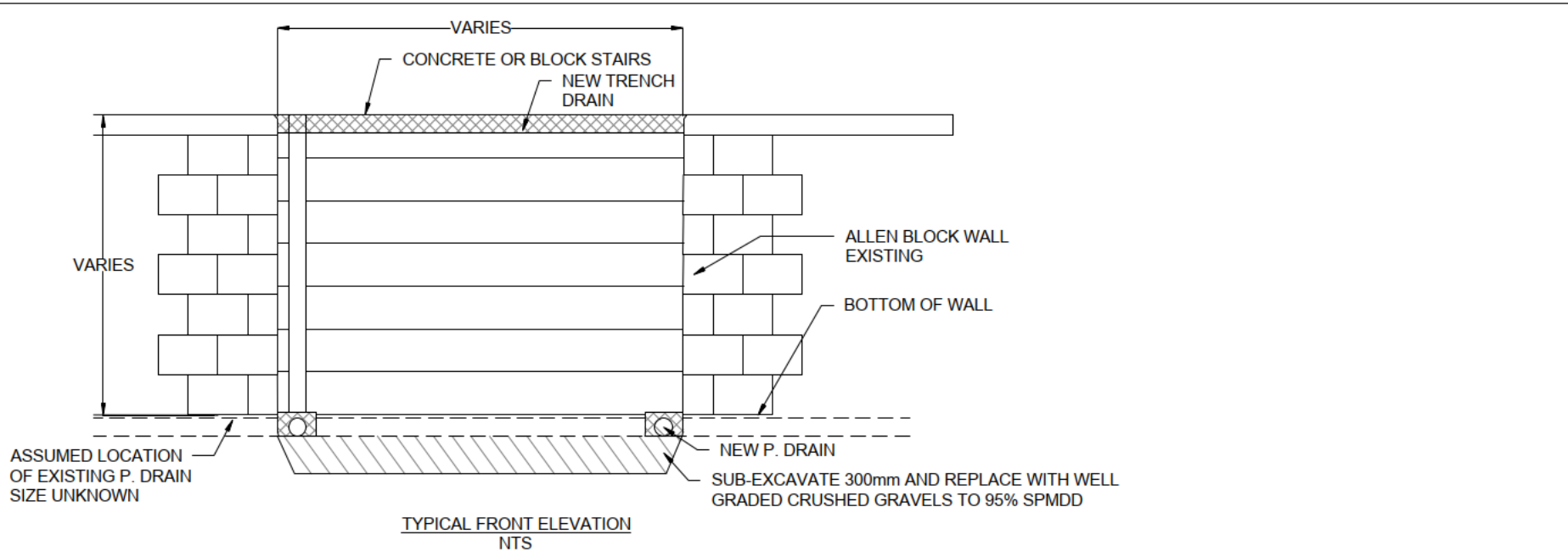



 <b>SNT Engineering Ltd.</b> SUITE 3 - 385 BAKER STREET, NELSON, BC, V1L 4H8 Tel: (250) 354-7883 PERMIT TO PRACTICE# 1001678 www.snteng.ca	Title: CRESTON & DISTRICT COMMUNITY CENTER STAIR REPAIRS		Rev.	Date	Description
	Address: _____				
Client: REGIONAL DISTRICT OF CENTRAL KOOTENAY					
Drawn By: NH	Date: 04/15/2024	Proj. No.: RDCK-24-01	Dwg. No.: _____	Scale: NTS	Rev #: 0
Designed By: C. STAUFFER, P. ENG.					



CDCC Block Retaining wall and Stairs



Stairs "A"



West side of Stairs "A"



Stairs "B"



Gap Between Stairs "B" and Concrete wall

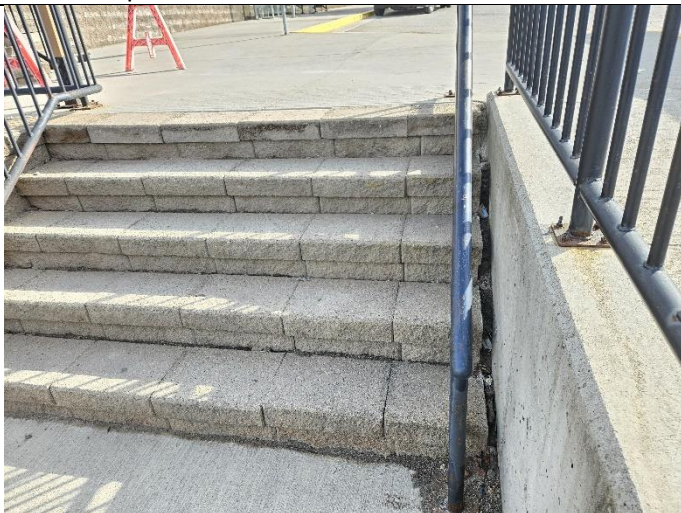

Settlement at top of stairs

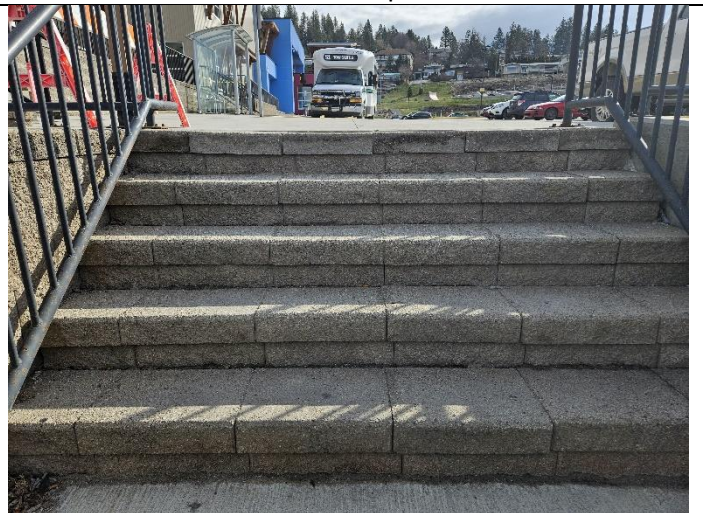



Stairs at back of building, no settlement

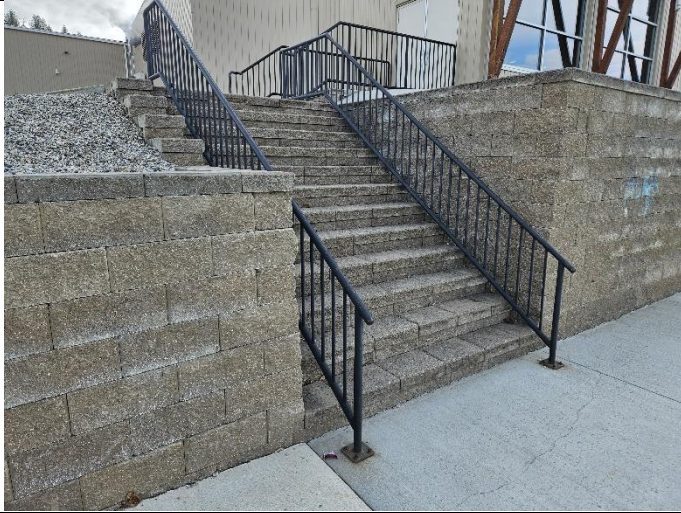

4" Existing slab at top of "A".



East side of Stairs "A"



East side of Stairs "A"



West side of Stairs "A"

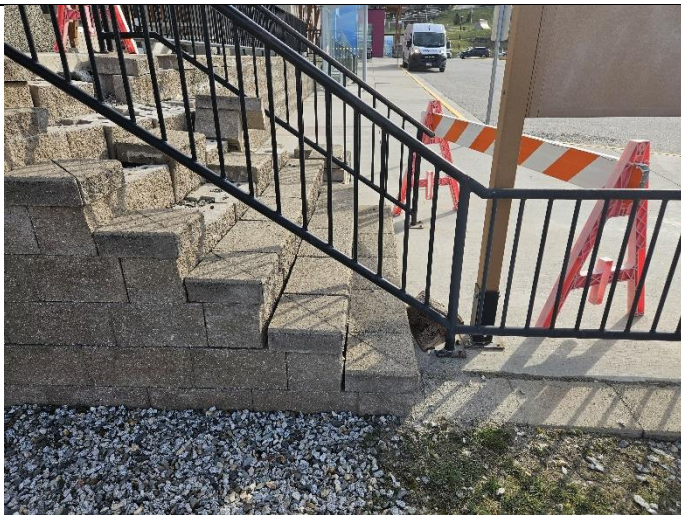

Stairs "C"

