



REGIONAL DISTRICT OF CENTRAL KOOTENAY
BOX 590, 202 Lakeside Drive, NELSON, BC V1L 5R4
 ph: 250-352-8165 fax:: 250-352-9300 email: rdck@rdck.bc.ca

RDCK Planning File No. Z2209G
Amendment to OCP Bylaw No. 1157, 1996
Amendment to Zoning Bylaw No. 1675, 2004
Date: September 26, 2022

You are requested to comment on the attached Amendment Bylaw(s) for potential effect on your agency's interests. We would appreciate your response **WITHIN 30 DAYS (PRIOR TO October 27, 2022)**. If no response is received within that time, it will be assumed that your agency's interests are unaffected. This referral notice has also been provided to adjacent property owners within 100 metres (328 feet) or greater of the subject property for review and comment.

PURPOSE OF THE BYLAW:

This application has been revised and is being re-referred. The revisions adjust the proposed zone to reflect the residential use. Formerly a comprehensive development zone was proposed. This has been revised to Ootischenia Suburban Residential 's' (R1As) zone with the 's' notation indicating 'secondary suite'. Two draft versions of amending bylaws are attached to this referral package for reference.

The proposal is to build a two (2) bedroom one-family dwelling with a one bedroom (65 square metre) secondary suite on a property that is 0.23 hectares in size and currently vacant. The Ootischenia Suburban Residential (R1A) zone, given the site area of the subject property, currently allows for a one family dwelling but does not have a provision for secondary suites.

LEGAL DESCRIPTION & GENERAL LOCATION:

1010 Columbia Road, Ootischenia Electoral Area 'J'
 Lot 2 District Lot 4598 Kootenay Land District EPP75763 (PID 030-260-191)

AREA OF PROPERTY AFFECTED	ALR STATUS	ZONING DESIGNATION	OCP DESIGNATION
0.23 hectares	Not applicable	RDCK Zoning Bylaw No. 1675, 2004 Ootischenia Suburban Residential (R1A)	Kootenay-Columbia Rivers Official Community Plan Bylaw No. 1157, 1996. Suburban Residential (SR)

APPLICANT/AGENT:

Carlin Horkoff

OTHER INFORMATION: ADVISORY PLANNING COMMISSION PLEASE NOTE:

If your Advisory Planning Commission plans to hold a meeting to discuss this Bylaw Amendment application, please note that the applicants must be provided with an opportunity to attend such meeting, in accordance with Section 461, subsection (8) of the *Local Government Act*, which reads as follows:

"If the commission is considering an amendment to a plan or bylaw, or the issue of a permit, the applicant for the amendment or permit is entitled to attend meetings of the commission and be heard."

Please fill out the Response Summary on the back of this form. If your agency's interests are 'Unaffected' no further information is necessary. In all other cases, we would appreciate receiving additional information to substantiate your position and, if necessary, outline any conditions related to your position. Please note any legislation or official government policy which would affect our consideration of this bylaw.

Eileen Senyk, PLANNER
REGIONAL DISTRICT OF CENTRAL KOOTENAY

<input checked="" type="checkbox"/> TRANSPORTATION West Kootenay <input checked="" type="checkbox"/> HABITAT BRANCH <input type="checkbox"/> FRONT COUNTER BC (FLNRORD) <input type="checkbox"/> AGRICULTURAL LAND COMMISSION <input type="checkbox"/> REGIONAL AGROLOGIST <input type="checkbox"/> ENERGY & MINES <input checked="" type="checkbox"/> MUNICIPAL AFFAIRS & HOUSING <input checked="" type="checkbox"/> INTERIOR HEALTH HBE Team, Nelson <input type="checkbox"/> KOOTENAY LAKES PARTNERSHIP	FIRST NATIONS <input checked="" type="checkbox"/> KTUNAXA NATION COUNCIL (ALL REFERRALS) YAQAN NU?KIY (LOWER KOOTENAY) ?AKINK'UM?ASNUQ?I?IT (TOBACCO PLAINS) ?AKISQNUK (COLUMBIA LAKE) ?AQ'AM (ST. MARY'S) <input checked="" type="checkbox"/> OKANAGAN NATION ALLIANCE <input type="checkbox"/> C'ƏC'ƏWIXA? (UPPER SIMILKAMEEN)
---	--

<input checked="" type="checkbox"/> SCHOOL DISTRICT NO. 20 <input checked="" type="checkbox"/> WATER SYSTEM OR IRRIGATION DISTRICT (OOTISCHENIA IMPROVEMENT DISTRICT) <input type="checkbox"/> UTILITIES (FORTIS, BC HYDRO, NELSON HYDRO, COLUMBIA POWER) REGIONAL DISTRICT OF CENTRAL KOOTENAY DIRECTORS FOR: <input type="checkbox"/> A <input type="checkbox"/> B <input type="checkbox"/> C <input type="checkbox"/> D <input type="checkbox"/> E <input type="checkbox"/> F <input type="checkbox"/> G <input type="checkbox"/> H <input type="checkbox"/> I <input checked="" type="checkbox"/> J <input type="checkbox"/> K ALTERNATIVE DIRECTORS FOR: <input type="checkbox"/> A <input type="checkbox"/> B <input type="checkbox"/> C <input type="checkbox"/> D <input type="checkbox"/> E <input type="checkbox"/> F <input type="checkbox"/> G <input type="checkbox"/> H <input type="checkbox"/> I <input checked="" type="checkbox"/> J <input type="checkbox"/> K <input checked="" type="checkbox"/> APHC AREA J <input checked="" type="checkbox"/> RDCK FIRE SERVICES – DISTRICT CHIEF (BY AREA) <input type="checkbox"/> RDCK EMERGENCY SERVICES <input checked="" type="checkbox"/> RDCK BUILDING SERVICES <input type="checkbox"/> RDCK UTILITY SERVICES <input type="checkbox"/> RDCK REGIONAL PARKS	<input checked="" type="checkbox"/> K4K'AR'MÍWS (LOWER SIMILKAMEEN) <input checked="" type="checkbox"/> SNPÍTKTN (PENTICTON) <input type="checkbox"/> STQA?TKWƏ+WT (WEST BANK) <input checked="" type="checkbox"/> SUKNAQÍN (OKANAGAN) <input checked="" type="checkbox"/> SWÍWS (OSOYOOS) <input checked="" type="checkbox"/> SPAXOMƏN (UPPER NICOLA) <input type="checkbox"/> SHUSWAP NATION TRIBAL COUNCIL <input checked="" type="checkbox"/> KENPÉSQT (SHUSWAP) <input checked="" type="checkbox"/> QW?EWT (LITTLE SHUSWAP) <input checked="" type="checkbox"/> SEXQELTQÍN (ADAMS LAKE) <input checked="" type="checkbox"/> SIMPCW ((SIMPCW) <input type="checkbox"/> SKEMTSIN (NESKONLITH) <input checked="" type="checkbox"/> SPLATSÍN (SPLATSÍN FIRST NATION) <input checked="" type="checkbox"/> SKEETCHESTN INDIAN BAND <input checked="" type="checkbox"/> TK'EMLUPS BAND
--	--

The personal information on this form is being collected pursuant to *Regional District of Central Kootenay Planning Procedures and Fees Bylaw No. 2457, 2015* for the purpose of determining whether the application will affect the interests of other agencies or adjacent property owners. The collection, use and disclosure of personal information are subject to the provisions of FIPPA. Any submissions made are considered a public record for the purposes of this application. Only personal contact information will be removed. If you have any questions about the collection of your personal information, contact the Regional District Privacy Officer at 250.352.6665 (toll free 1.800.268.7325), info@rdck.bc.ca, or RDCK Privacy Officer, Box 590, 202 Lakeside Drive, Nelson, BC V1L 5R4.

RESPONSE SUMMARY

PLANNING FILE NO.: Z2209J APPLICANT: CARLIN HORKOFF

Name: Date:

Agency:

Title:

**RETURN TO: EILEEN SENYK, PLANNER
DEVELOPMENT SERVICES
REGIONAL DISTRICT OF CENTRAL KOOTENAY
BOX 590, 202 LAKESIDE DRIVE
NELSON, BC V1L 5R4
plandept@rdck.bc.ca**



Bylaw Amendment Z2209J - Horkoff

Map Projection: UTM Zone 11 Map Datum: NAD83
Date Plotted: Monday, August 8, 2022

Regional District of Central Kootenay – Planning Department

[REDACTED]

[REDACTED]

[REDACTED]

Request for Consideration, Bylaw Amendment (Zoning) to Permit a Two Family Dwelling – LOT 2, PLAN EPP75763, DISTRICT LOT 4598, KOOTENAY LAND DISTRICT

To Whom it May Concern,

My wife and I constructed our family home at 1012 Columbia Road in 2018. We have recently purchased the property immediately to the south of our home and are considering construction of a single structure build as a two-bedroom resident with a legal one-bedroom suite. This letter serves to present our request for revised zoning of the property in order to allow for construction of two dwelling units on the 0.230 ha property which is in contravention of bylaw 1675 Development Regulation 801 (1).

1 Proposed Development

We propose to construct the building on LOT 2, PLAN EPP75763, DISTRICT LOT 4598, KOOTENAY LAND DISTRICT. This property is 0.230 ha and is serviced by one Ootischenia Improvement District (OID) Community Water Supply. Details of the proposed building are as follows:

- Total Building footprint (including deck) 1980 Sq.ft. which includes:
 - 2.5 bathroom.
 - 3 bedroom.
 - 3 bay garage.

We propose to legally separate the living area as per BC Building Code into two separate dwellings. Dwelling #1 is proposed to be a 1028 Sq.ft two bedroom, one bathroom unit. Dwelling #2 is proposed to be a 700 Sq.ft one bedroom, one bathroom unit. The garage would have a half bathroom.

2 Intended Use

In the short to intermediate term (1-2 years) we intend to occupy the property and use the secondary dwelling as an “in-law suite” which would allow our parents to move closer to us. We intend to retain the property in the long term. We are pursuing a legal separation between the dwellings with the intend to create future flexibility to rent a two-bedroom suite to a couple or small family with no more than four occupants and a one-bedroom suite to a student or couple with no more than two occupants.

3 Requested Re-Zoning

As per RDCK Area J building bylaw 1675 Development Regulation 801 (1), a two-family dwelling is allowable on the proposed lot, however the minimum allowable lot size for a two family dwelling serviced by Community Water Supply Only is 0.4 ha. As such we are requesting appropriate zoning to allow for construction of the above-described building on the 0.230 ha LOT 2, PLAN EPP75763, DISTRICT LOT 4598, KOOTENAY LAND DISTRICT.

4 Proposed Justification

Presented below is our proposed justification to allow this variance.

4.1 Building Size and Water Usage

The size of the proposed building, number of bathrooms as well as the proposed maximum occupancy of six residents is consistent with a typical single-family home serviced by the OID. This proposed building is smaller than, and has less bathrooms than many residential developments on similar size lots serviced by the OID, including our family home situated adjacent to this proposed build. As such, we believe it can be inferred that the proposed building and its occupants will require a lower average water usage than other comparably sized properties/ homes serviced by the OID.

We understand landscaping, particularly lawn watering puts a large seasonal strain on the OID water supply. As this building will be a future rental property and we intend to landscape with strong consideration for limited maintenance. We expect this property to have very little lawn area watered using underground sprinkling meeting OID flow rate and watering hour requirements. As such we believe it can be inferred that the proposed landscaping will require a lower seasonal water usage than other comparably sized developed properties serviced by the OID.

Based on the above, the single available water hookup on the lot is sufficient to service the proposed build.

4.2 Approved Record of Sewerage System

We retained a Registered Onsite Wastewater Practitioner to complete a septic design for the above described dwelling and have received a Receipt of Record of Sewerage System from Interior Health allowing construction of the proposed system to serve the above noted dwelling. The design and Interior Health Receipt is enclosed with our Re-zoning application.

4.3 Alignment with RDCK Official Community Plan

Based on our review of the Kootenay-Columbia Rivers Official Community Plan Bylaw no. 1157, 1996, we have not identified any components of our proposed build that conflict with the plan and we believe that our approach to this proposed building is well aligned with several components of the Official Community Plan as highlighted below.

Section 2 – Residential Objectives

2.1.7 – “To encourage some limited higher density residential development subject to adequate servicing and the maintenance of rural character.”

2.8.7 – “To co-operate with appropriate utility companies to adequately provide services to the Plan Area. “

Section 3.2 General Residential Policies

3.2.1 - “The following residential land use policies apply to all land where residential use is allowed irrespective of land use designation. These general policies are followed by policies specific to individual designations. “

3.2.1.1 - Existing lots smaller than the minimum lot size permitted by designation, may be used for the purposes permitted in the designation providing all other regulations are met.

Section 3.12 Greenhouse Gas Emission Reduction Targets

General Policies

Development and Buildings

The Regional Board Will:

3.12.11 – “Encourages the clustering of residential development to create separation between neighbouring developments and to avoid continuous sprawl-like development.”

3.12.16 – “Encourages nodal development instead of sprawl along major roads and, where appropriate, encourages clustering of commercial and urban residential development along major roads, in order to achieve a more efficient use of land and a proper distribution of traffic flow throughout the road network.”

3.12.17 – “Encourages compact development rather than the creation of low-density residential lots fronting the major road network and the provision of multiple accesses onto the major road network.”

4.4 Transparent Approval Approach

We understand that within the OID service area and greater RDCK Area J there may be some single-family residences which operate secondary suites and/or similar multi-family orientations on lot sizes less than 0.4 ha. We hope that it is recognized that our approach to this project provides the RDCK, OID and other stakeholders complete transparency regarding the proposed development. Additionally, we hope it is recognized that our proposed construction will create safe, legal dwellings meeting current BC Building Code Requirements.

5 Closure

We trust this letter provides reasonable justification for the proposed variance to RDCK Area J building bylaw 1675 Development Regulation 801 (1). We would like to express our willingness to work with the RDCK and other stakeholders to meet any requirements to allow for this proposed build. Please do not hesitate to contact us with question, concerns or potential alternatives.

Thank you for your consideration,

Carlin and Allison Horkoff

1012 Columbia Road, Castlegar, BC, V1N 4K6





This drawing must not be scaled.
 The contractor shall verify all levels, datums, and dimensions prior to commencement of work. All errors and omissions must be reported to the Designer immediately.
 This drawing is the exclusive property of Parq Design Studio and must not be reproduced without their written permission.

PROJECT NORTH

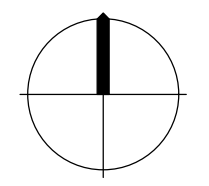

Issue No.	Date	Description
1	2022-04-13	ISSUED FOR BUILDING PERMIT

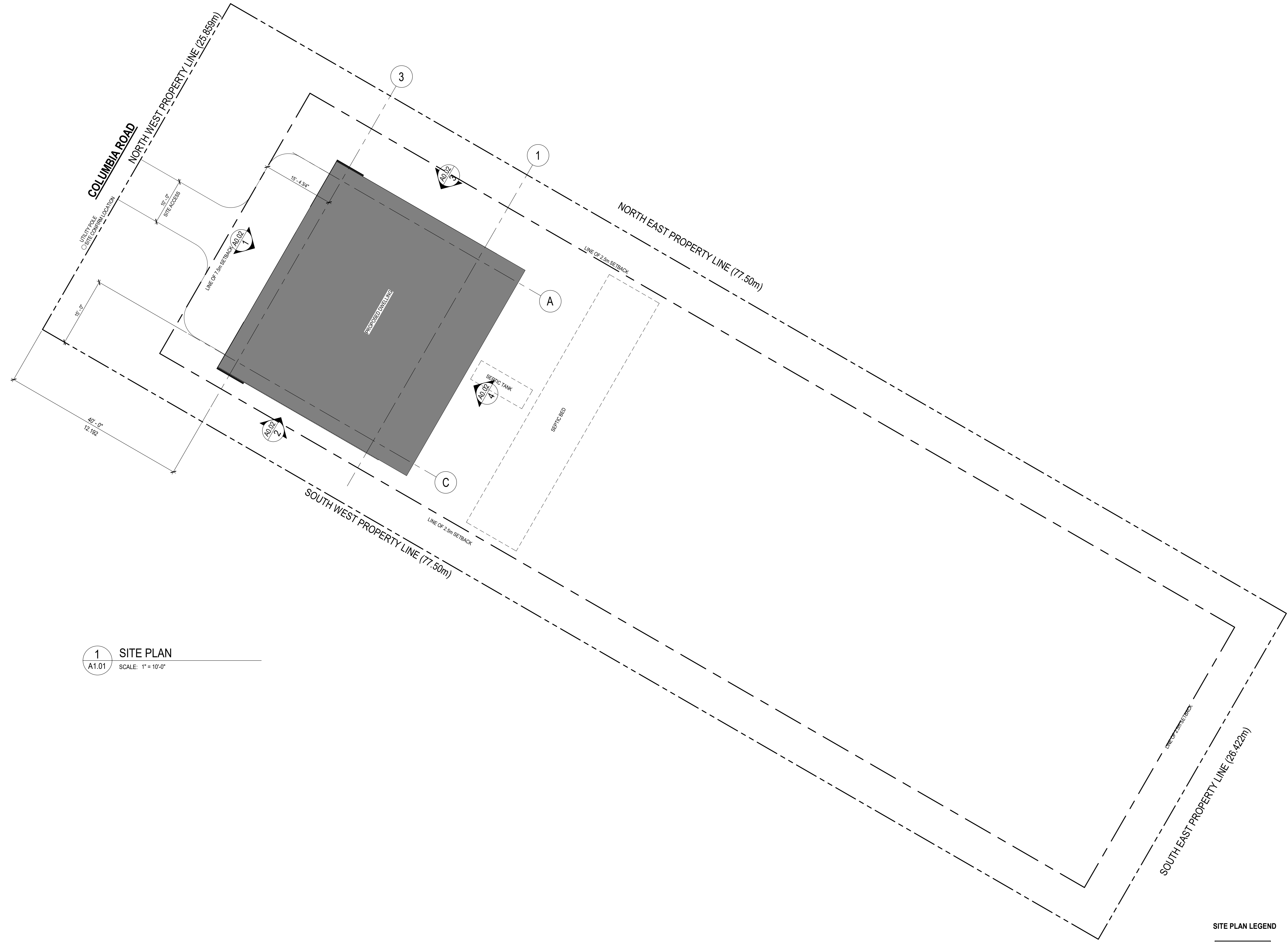

1 SITE PLAN
 A1.01 SCALE: 1" = 10'-0"

SITE PLAN LEGEND

- PROPOSED DWELLING UNIT
- PROPERTY LINE
- SETBACK LINE

**HORKOFF CARRIAGE HOUSE
 CASTLEGAR, BRITISH
 COLUMBIA**

drawing title
 SITE PLAN

scale: As indicated
 project no: 21-113
 date issued: 2022-04-13

re-issue no: 1 sheet no: **A1.01**

PROJECT LOCATION MAP



ISSUED FOR: 2022-02-14

ISSUED FOR BUILDING PERMIT

DRAWING LIST

A0.00	COVER
A0.01	GENERAL INFORMATION & CONSTRUCTION ASSEMBLIES
A0.02	BUILDING CODE ANALYSIS & LIMITING DISTANCE
A0.03	WINDOW AND DOOR SCHEDULE
A1.00	FOUNDATION
A2.01	GARAGE FLOOR PLANS
A2.02	SUITE PLANS
A2.03	ROOF PLAN
A3.01	ELEVATIONS
A4.01	BUILDING SECTION
A9.01	PERSPECTIVE VIEWS



This drawing must not be scaled.
The contractor shall verify all levels, dates, and dimensions
prior to commencement of work. All errors and omissions must
be referred to the Designer immediately.
This drawing is the exclusive property of Parq Design Studio
and must not be reproduced without their written permission.

PROPOSED RENDERINGS

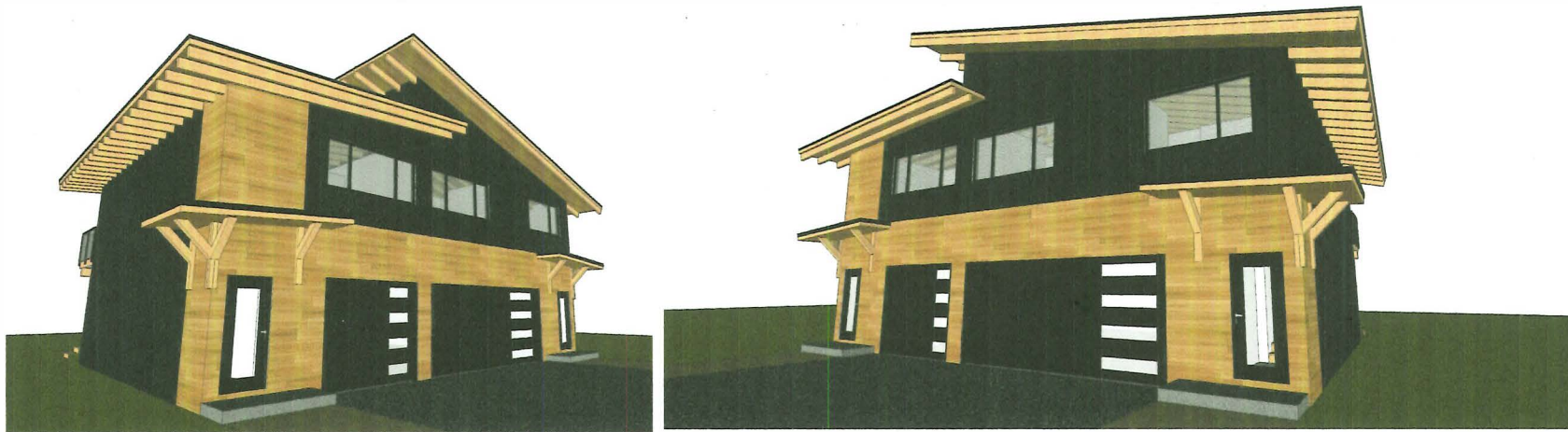

HORKOFF CARRIAGE HOUSE
CASTLEGAR, BRITISH
COLUMBIA



This drawing must not be scaled.
The contractor shall verify all levels, datums, and dimensions
prior to commencement of work. All errors and omissions must
be reported to the Designer immediately.
This drawing is the exclusive property of Parq Design Studio
and must not be reproduced without their written permission.

PROJECT NORTH

Issue	Date	Description
1	2022-04-13	ISSUED FOR BIDDING PERMIT



1 Exterior View 1
AS.01 SCALE.

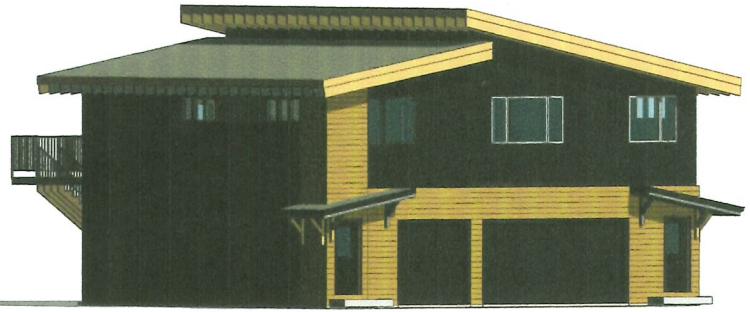

2 Exterior View 2
AS.01 SCALE.



3 Exterior View 3
AS.01 SCALE.



4 Exterior View 4
AS.01 SCALE.

HORKOFF CARRIAGE HOUSE
CASTLEGAR, BRITISH
COLUMBIA

drawing title
PERSPECTIVE VIEWS
NOTE: PERSPECTIVE VIEWS ARE FOR REFERENCE ONLY

scale:	25-113
project no:	2022-04-13
date issued:	
revision no:	

1 A9.01



Interior Health
Every person matters

RECEIPT OF RECORD OF SEWERAGE SYSTEM

This receipt acknowledges that the Health Authority has received a completed Record of Sewerage System for the following location:

RECEIPT NUMBER FOR RSS FILING FEE: NHP-0360

TAX ASSESSMENT ROLL NUMBER: 21-709-07288.912

AUTHORIZED PERSON: TODD W. EVELAND OW0432

CIVIC ADDRESS: LOT 2 COLUMBIA RD, OOTISCHENIA

LEGAL DESCRIPTION: LOT 2 PLAN EPP75763 DISTRICT LOT 4598 LD 26 PID: 030-260-191

EFFECTIVE DATE: 18 MAY 2022

Please note that the system work must be completed and a Letter of Certification filed with the Health Authority within two years of the effective date noted.

EXPIRY DATE: 18 MAY 2024

		Filing # (OFFICE USE ONLY)			
1. Property Information	<input checked="" type="checkbox"/> New Construction	<input type="checkbox"/> Alteration	<input type="checkbox"/> Repair	<input type="checkbox"/> Amendment – Original Filing #	
	Tax Assessment Roll # 21-709-07288.912			PID # 030-260-191	
	Legal Description (Plan, Lot, District Lot, Block Numbers) Lot 2, Plan EPP75763, DL 4598, Land District 26				
	Street (Civic) Address or General Location 1010 Columbia Road			City Castlegar	
2. Owner Information	Name of Legal Owner Carlin & Allison Horkoff		Mailing Address 1012 Columbia Road		
	Phone 250-859-0476	City Castlegar	Prov BC	Postal Code V1N 4K5	
3. Authorized Person Information	Name of Authorized Person Todd Eveland		Mailing Address 2811 Blewett Road		
	Phone 250-551-4268	City Nelson	Prov BC	Postal Code V1L 6V5	
	Registration # OW0432		Email t_eveland@shaw.ca		
	Sewerage System Will Serve: <input type="checkbox"/> Single Family Dwelling <input checked="" type="checkbox"/> Other Structure (specify) Carriage House <input type="checkbox"/> Other Dwelling (specify) WITH TWO APARTMENTS / ONE-2 BEDROOM - ONE-1 BEDROOM The sewerage system is designed for an estimated minimum daily domestic sewage flow of (check one) <input checked="" type="checkbox"/> Less than or equal to 9,100 litres <input type="checkbox"/> More than 9,100 litres but less than 22,700 litres				
5. Site Information	Depth of native soil to seasonal high water table or restrictive layer (cm) 182		Information respecting the type, depth and porosity of the soil is attached <input checked="" type="checkbox"/> Yes <input type="checkbox"/> No		
	GPS Location of System (decimal degrees) Latitude 49.277849 Longitude -117.629713		Horizontal Accuracy (m) 5m <input checked="" type="checkbox"/> Recreational GPS <input type="checkbox"/> Differential GPS		
	Will the sewerage system be located less than 30 m from a well? <input type="checkbox"/> Yes <input checked="" type="checkbox"/> No				
6. Drinking Water Protection	If yes, attach a professional's report and specify the intended distance (m)				
	Distance of proposed sewerage system to the closest body of surface water 182 (m)				
7. System Information	Sewerage treatment method <input checked="" type="checkbox"/> Type 1 <input type="checkbox"/> Type 2 <input type="checkbox"/> Type 3				
8. Legal or Regulatory Considerations	<input checked="" type="checkbox"/> Construction of the proposed sewerage system will not conflict with legal instruments registered on the property.		Is this filing submitted as the result of an order from the Health Authority? <input type="checkbox"/> Yes (attach a copy of the order) <input checked="" type="checkbox"/> No		
	Plot Plan (to scale) and specifications are attached <input checked="" type="checkbox"/> Yes <input type="checkbox"/> No				
9. Plot Plan and Specifications	<input checked="" type="checkbox"/> The plans and specifications are consistent with Standard Practice				
	Source of Standard Practice: <input checked="" type="checkbox"/> Ministry of Health Standard Practice Manual <input type="checkbox"/> Other				
10. Authorized Person's Signature	Signature (email submission does not require a signature) 			OFFICE USE ONLY	
	Date May 5 2022			Filing Accepted Date	
			Receipt Number		

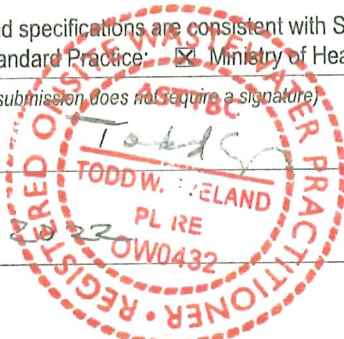

SEPTIC DESIGN

Sewerage System Design

Health Authority Initial Filing For Construction of Sewerage System:
Site investigation report, record of design and specification

Introduction

Legal Owner's Name: Carlin & Allison Horkoff

Date: May 5, 2022

Civic Address: 1010 Columbia Road, Castlegar, BC

Mailing Address: 1012 Columbia Road, Castlegar, BC

Legal Description: Lot 2, Plan EPP75763, District Lot 4598, Land District 26

Tax Assessment Roll Number 21-709-07288.912

PID Number 030-260-191

Summary of Proposed Works: (also see site plan attached)

This design is for a proposed new carriage house which will be two apartments – one - 2 bedroom and one 1 bedroom. This carriage house is on newly developed lot on Columbia Road in Ootischenia, east of Castlegar. This is a basically level lot with good sand soil that has good percolation. This design is for a gravity fed seepage bed. The owner has a preferred septic field location and the chosen area is large enough and meets all the required setbacks just behind the proposed house.

Proposed wastewater system:

- One bedroom apartment 700 L/d – Two bedroom apartment 1000 L/d
- Total Daily design flow 1700L/day (374 IG)
- Type 1 effluent
- One – Canwest RKS1250 - 2 Chamber 5682 L (1250 IG) HDPE septic tank,
- One 7 hole distribution box
- Gravity dispersal to a septic bed 18.9m (62') X 3.0m wide (10') wide.

Site Information

Total parcel size: 0..203Ha. (0.5 Acre)
Potable Water Source: Ootischenia Water District

Soil/Site Evaluation:



SEPTIC DESIGN

Soil/Site Evaluation:

Test pit #1

- 0-23 cm –Sandy Loam, Dark Brown, Friable, Many fine roots..
- 23-42 cm Loamy Sand, Friable, Brown, Few fine roots
- 42-168 cm –Medium to Course Sand, friable, light brown, no roots.

Permeameter test KFS = 2024 mm/day

Test pit #2

- 0-22 cm –Sandy Loam, Dark Brown, Friable, Many fine roots..
- 22-45 cm Loamy Sand, Friable, Brown, Few fine roots
- 45-182 cm –Medium to Course Sand, friable, light brown, no roots.

Permeameter test KFS = 1675 mm/day

Limiting Layer/ design limit:

Vertical separation is more than 1820cm of the deepest pit. No restrictive layer or water was found.

Design:

Daily Design Flow: Table II-8

- One bedroom apartment 700 L/d – Two bedroom apartment 1000 L/d
- Total Daily design flow 1700L/day (374 IG)

Hydraulic Load Rate: Table II-23

- Soil type –Sand, KFS = 1675 mm/day = 30 L/sq.m.

Linear Load Rate: Table II-27

- Soil is Sand
- Less than >5% slope.
- Predominate vertical flow 90 L/Day/m
- 1700 L/Day ÷ 90 L/Day/M =18.9m

Basil Area

- $HLR = 1700 \text{ L/Day} \div 30 \text{ L/m}^2 = 56.7 \text{ m}^2$
- $56.7 \text{ sq m} \div 3.0 \text{ m wide bed} = 18.9 \text{ m long}$

Septic Tank



SEPTIC DESIGN

- DDF = 1700 L/Day
- 3 day retention = 1700 L/Day X 3 Days = 5100 L = 1122 IG
- This tank design is over size for future expansion.
- Canwest RKS1250/2, HDPE 2 compartment septic tank. 5682 L (1250 IG)
- install outflow effluent filter with handle extended to within 6" of access lid
- install Poly-Lok PL122 effluent filter or approved equivalent.
- ensure easy access by installing risers as required to bring lids to slightly above surface

Seepage Bed:

- Remove sod and excavation to needed depth seepage.
- Scarify infiltrative surface and place gravel
- See drawing detail for a seepage bed 18.9m X 3.0m

D-Box

- 7 hole D-box
- Install equalizer
- ensure accessibility to D box by appropriate service box

Pipe:

- 4" sewer connections to be CSA
- level placement of laterals to encourage even distribution,
- 2% fall for 4" lines entering septic tank
- ensure 1% fall for effluent line from tank to D box and 1% for 4" headers from D box to laterals
- Install monitoring wells

Miscellaneous specs

- Install all tanks on minimum of 5cm of bedding sand, level, consistent support, ...native backfill is OK for sides but with no cobbles or larger rock contacting tank walls, cover with sand
- Ensure easy access to tank lids for inspection and maintenance by installing risers to bring lids to slightly above finished surface
- Effluent filter handle extension to within 15 cm (6") of the access rims to avoid confined space entry issues.
- Ensure all piping is adequately bedded with sand, well supported
- Ensure well supported, level placement of D box with careful leveling of flow by speed levelers. Confirm by water testing
- Do not alter structure of original soil in dispersal area, do not back trucks onto area, minimize loads/smearing/compaction, scarify shallow, do not install in wet conditions
- Establish appropriate vegetation cover of the dispersal field (grass)
- Protect the dispersal field and tanks from traffic, heavy loads, surface or sub surface flows of water



SEPTIC DESIGN

Declaration:

These plans and specifications are consistent with standard practice with regard to the Sewerage System Regulation and the Sewerage System Standard Practices Manual of the B.C. Ministry of Health. I have conducted a site evaluation and exercised due diligence. I am a registered on-site practitioner authorized to plan and install the system designed herein.





COLUMBIA ROAD

LOT 3

PROPOSED HOUSE



SEPTIC TANK
SEEPAGE BED

LOT 2

PLAN EPP75763

DL 4598 KLD

LOT 1

LOT 4

1. SYSTEM TO BE INSTALLED IN ACCORDANCE WITH PRODUCT DESIGN AND INSTALLATION MANUAL, PROVINCIAL AND LOCAL REGULATIONS.
2. SEPTIC SYSTEM TO BE INSTALLED BY A REGISTERED ONSITE WASTEWATER INSTALLER.
3. INSTALLER ADVISED TO CONTACT CALL ONE PRIOR TO CONSTRUCTION.
4. NO DRAINS, HOT TUBS, SAUNAS, GARBAGE DISPOSALS ETC.. SHALL BE INCORPORATED INTO THIS SYSTEM UNLESS OTHERWISE SPECIFIED.
5. MAINTENANCE: RECOMMEND INSPECTION OF SEPTIC TANKS AT LEAST ONCE EVERY TWO YEARS AND CLEAN IF COMBINED THICKNESS OF SLUDGE AND SCUM EQUALS MORE THAN 1/4 OF THE LIQUID DEPTH INSIDE THE TANK.
6. THIS DOCUMENT IS FOR THE CONSTRUCTION OF THE EFFLUENT DISPOSAL SYSTEM SHOWN. ANYONE USING INFORMATION FROM THIS DOCUMENT FOR ANY OTHER PURPOSE DOES SO AT THEIR OWN RISK.

Carlin and Allison Horkoff
1010 Columbia Road,
Folio 21-709-07288.912
PID: 030-260-191

SEPTIC INSTALL DETAILS

Project No. 248-2022	Drawing No. 248-01
Scale 1:500	Sheet 1 of 5
Date 2022-05-05	REV.

SITE LOCATION

WATERLINE



PROPOSED HOUSE

DECK

MIN 2% GRADE

100 (4") PIPE FROM HOUSE

CLEAN OUT

MIN 1% GRADE
100 (4") PIPE
FROM SEPTIC
TO D-BOX

CANWEST TANK MODEL
RKS 1250 5682L (1250 IG)
2 CHAMBER SEPTIC TANK

7 HOLE D-BOX

MIN.3m

MIN.3m

SEEPAGE BED
18.9m x 3m

Carlin and Allison Horkoff
1010 Columbia Road,
Folio 21-709-07288.912
PID: 030-260-191

SEPTIC INSTALL DETAILS

Project No. 248-2022	Drawing No. 248-02
Scale 1:200	Sheet 2 of 5
Date 2022-05-05	REV.

SITE PLAN

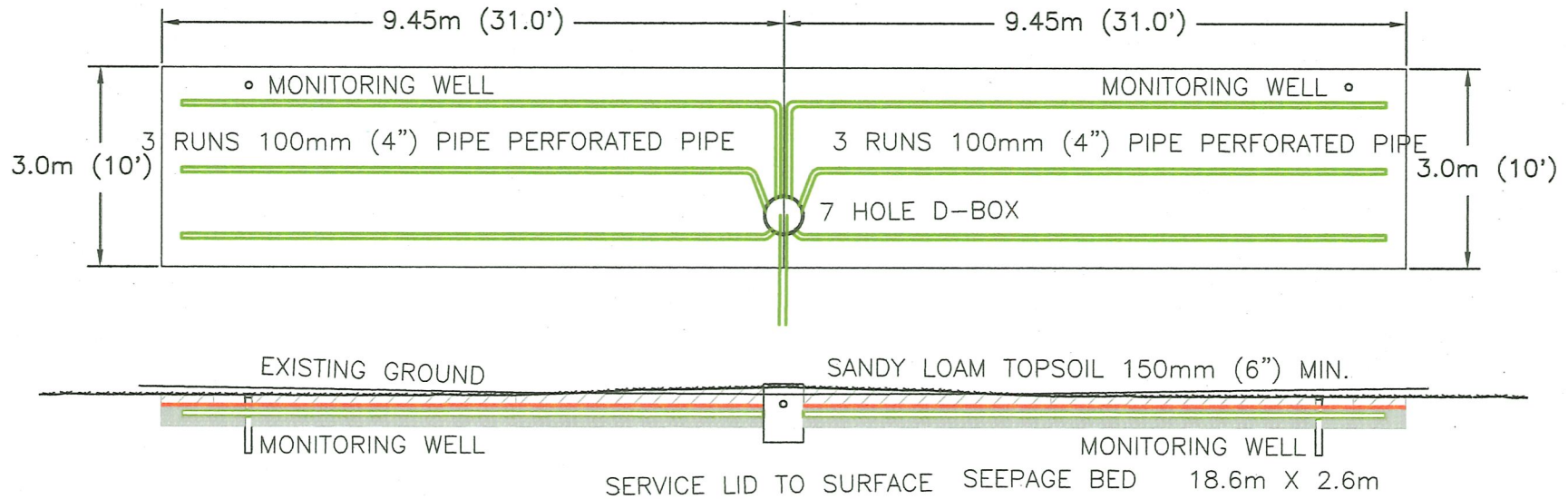

General Notes:

Carlin and Allison Horkoff
 1010 Columbia Road,
 Folio 21-709-07288.912
 PID: 030-260-191

SEPTIC INSTALL DETAILS

Project No. 248-2022	Drawing No. 248-02
Scale 1:100	Sheet 3 of 5
Date 2022-05-05	REV.

SEPTIC FIELD
 PLAN VIEW
 LAYOUT

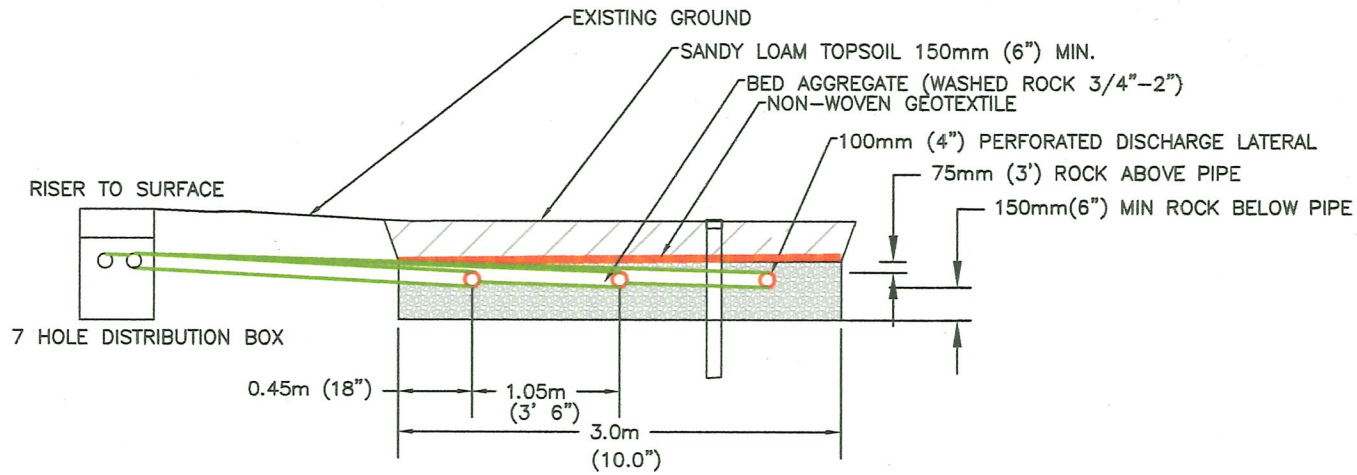

SEEPAGE BED SECTION VIEW



General Notes:

Carlin and Allison Horkoff
 1010 Columbia Road,
 Folio 21-709-07288.912
 PID: 030-260-191

SEPTIC INSTALL DETAILS

Project No. 248-2022	Drawing No. 248-04
Scale 1:50	Sheet 4 of 5
Date 2022-05-05	REV.

SEPTIC FIELD
 SECTION VIEW
 LAYOUT

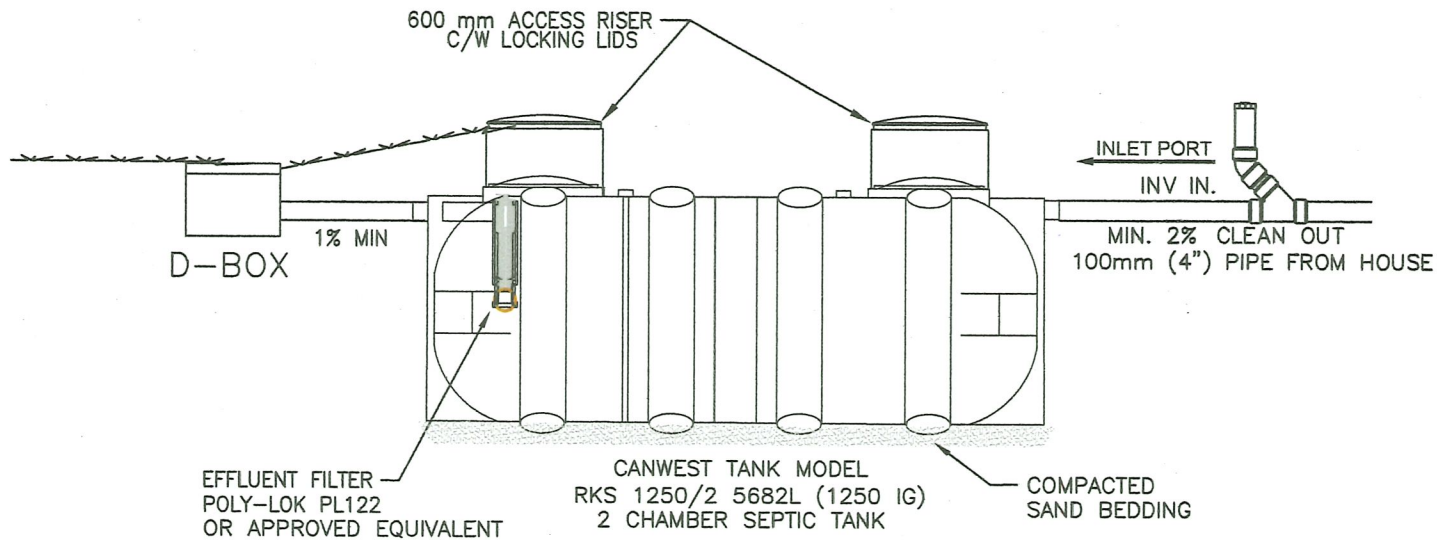

TANK LAYOUT SECTION VIEW

SCALE 1:40

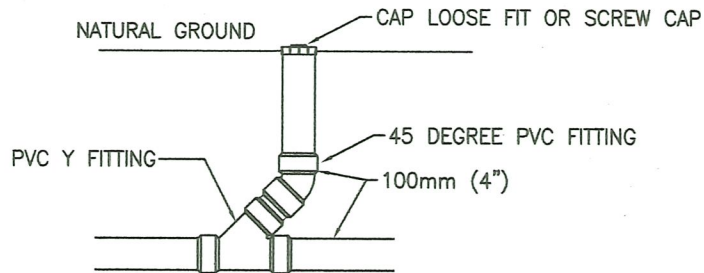

BUILDING CLEAN OUT SECTION VIEW

SCALE 1:25

General Notes:

Carlin and Allison Horkoff
1010 Columbia Road,
Folio 21-709-07288.912
PID: 030-260-191

SEPTIC INSTALL DETAILS

Project No. 248-2022	Drawing No. 248-05
Scale AS-SHOWN	Sheet 5 of 5
Date 2022-05-05	REV.

TANK LAYOUT
SECTION VIEW

- 3.2.1.3** Clustering of residential development shall be permitted in order to create separation between neighbouring developments and to ensure that they do not form continuous development.
- 3.2.1.4** Zoning regulations shall provide for a mix of residential lot sizes.
- 3.2.1.5** An adequate supply of potable water as specified in regulation, must be proven for each new lot created by subdivision.
- 3.2.1.6** The Approving Officer is requested to ensure that before a subdivision is approved, it must be demonstrated that where required through regulation, withdrawal of ground water for new lots will not adversely affect the supply to existing and potential water users.
- 3.2.1.7** Flood proofing regulations on setback of buildings and structures from water bodies and elevation of ground floors above water bodies shall be articulated either through zoning regulations or by adoption of a Floodplain Management Bylaw pursuant to Section 969 of the *Municipal Act*.
- 3.2.1.8** A conservation zone may be assigned to land covenanted or deeded against further development or use, including common property in strata title subdivisions.

3.2.2 Suburban Residential Policies (As shown on Schedule 'B' - Land Use Designations)

- 3.2.2.1** The principal use shall be residential.
- 3.2.2.2** The minimum lot size shall be 2000 square metres.
- 3.2.2.3** One dwelling unit shall be permitted per 2000 square metres of site area.
- 3.2.2.4** Shall be serviced by a community water system.
- 3.2.2.5** In areas where individual septic systems are adversely affecting the environment or the quality of water, a sewer system may be required where the minimum lot size for a single detached dwelling shall be 700 square metres.

3.2.3 Country Residential 1 Policies (As shown on Schedule 'B' - Land Use Designations)

- 3.2.3.1** The principal use shall be residential and/or agriculture.
 - 3.2.3.2** One dwelling unit shall be permitted per lot and one additional dwelling shall be permitted for every one (1) hectare of lot area over one (1) hectare.
 - 3.2.3.3** The minimum lot size shall be one (1) hectare.
 - 3.2.3.4** The clustering of development in either single detached or multi-residential dwellings subject to the maintenance of buffers on non-
-

DIVISION 8 OOTISCHENIA SUBURBAN RESIDENTIAL (R1A)

Permitted Uses

800 Land, buildings and structures in the Ootischenia Suburban Residential (R1A) zone shall be used for the following purposes only:

Dwellings:

One-Family

Two-Family

Accessory Uses:

Accessory Buildings and Structures

Accessory Tourist Accommodation

Home Based Business

Horticulture

Keeping of Farm Animals

Sale of Site Grown Farm Products

Development Regulations

801

1 The minimum site area for the following uses shall be required as follows:

	Community Water Supply Only	On-Site Servicing Only
One-Family Dwelling	0.2 hectare	1.0 hectare
Two-Family Dwelling	0.4 hectare	1.0 hectare

2 The maximum site coverage is 50 percent of the site area.

3 Buildings and structures shall not cover more than 33 percent of the site area.

4 The keeping of farm animals shall comply with the requirements of section 613 except that under all circumstances swine shall not be kept on any lot.

5 Farm animals and poultry shall be caged, fenced or housed at all times.

6 No principal building may exceed ten (10) metres in height.

7 The maximum height of any accessory building or structure shall not exceed 6 metres.

8 The maximum gross floor area of any accessory building or structure shall not exceed 100 square metres.

9 The cumulative gross floor area of all accessory buildings or structures shall no exceed 200 square metres.

10 Buildings and structures in the case of a lot that may be further subdivided shall be sited so as to facilitate the further subdivision of the lot or adjacent lots.

- 11 Landscape screens or fences not exceeding a height of one (1) metre may be sited on any portion of a lot.
- 12 Fences not exceeding a height of two (2) metres may be sited to the rear of the required front lot line setback only.

REGIONAL DISTRICT OF CENTRAL KOOTENAY

Bylaw No. TBD
DRAFT

A Bylaw to amend Kootenay Columbia Rivers Official Community Plan Bylaw No. 1157, 1996

WHEREAS it is deemed expedient to amend Kootenay Columbia Rivers Official Community Plan Bylaw No. 1157, 1996, and amendments thereto.

NOW THEREFORE the Board of the Regional District of Central Kootenay, in open meeting assembled, HEREBY ENACTS as follows:

APPLICATION

1 Section 3.223 is deleted in its entirety and replaced with the following:

Supports low density residential development with lot sizes for subdivision and development determined by the requirements of on-lot servicing, such as Type 1 waste water disposal.

CITATION

2 This Bylaw may be cited as “**Kootenay Columbia Rivers Official Community Plan Amendment Bylaw No. XXXX, 2022.**”

READ A FIRSTTIME this _____ day of _____

READ A SECOND TIME this _____ day of _____

WHEREAS A PUBLIC HEARING was held this _____ day of _____

READ A THIRDTIME this _____ day of _____

ADOPTED this [Date] day of [Month], 20XX.

Board Chair

REGIONAL DISTRICT OF CENTRAL KOOTENAY

Bylaw No. (TBD) DRAFT

A Bylaw to amend Regional District of Central Kootenay Zoning Bylaw No. 1675, 2004.

WHEREAS it is deemed expedient to amend the Regional District of Central Kootenay Zoning Bylaw No. 1675, 2004 and amendments thereto.

NOW THEREFORE the Board of the Regional District of Central Kootenay, in open meeting assembled, HEREBY ENACTS as follows:

APPLICATION

- 1 Schedule 'A' Division 5 Interpretation be amended by inserting the following definitions:

SECONDARY SUITE means a self-contained, accessory dwelling unit that provides living accommodation. The secondary suite is located within a one-family dwelling that has its own separate entrance and separate living, sleeping sanitary and kitchen facilities from the one-family dwelling. A secondary suite does not include multi-family dwelling, tourist accommodation or a recreational vehicle.

- 2 Regional District of Central Kootenay Zoning Bylaw No. 1675, 2004 **DIVISION 6 GENERAL REGULATIONS** is hereby amended by adding Section 624 Secondary Suites:

A secondary suite is subject to the following regulations:

1. A secondary suite is added to the list of permitted uses in the **Ootischenia Suburban Residential (R1A)** zone if the zone has an "s" notation shown on Schedule A, the Zoning Map, as part of the zone identification. The "s" notation shall be shown on Schedule A the Zoning Map as follows: **R1As**. An "s" zoning classification on a parcel shall be established by rezoning the subject parcel to the "s" version of the zone. The regulations set out for the "s" version of the zone will be the same as the regulations for the version without the "s", except for the addition of secondary suite as a permitted use.
2. The secondary suite shall not exceed 90 square metres gross floor area.
4. The secondary suite shall have its own separate cooking, sleeping, and bathing facilities.
3. The secondary suite shall have direct access to outside without passing through any part of the principal dwelling unit.
4. The secondary suite shall be located within a single detached house.
 - a) The secondary suite shall not be connected to a single detached house by a

breezeway or carport.

- 5. No more than one secondary suite is permitted per parcel.
- 6. A secondary suite is not permitted in conjunction with accessory tourist accommodation.
- 9. One parking space for the secondary suite is required in addition to those required for the principal dwelling.
- 10. A secondary suite shall meet all requirements of the British Columbia Building Code and amendments thereto.
- 11. The secondary suite must be serviced by a community water system and written authorization permitting the secondary suite from the service provider is required.

- 3** That Schedule ‘A’ of Regional District of Central Kootenay Zoning Bylaw No. 1675, 2004 be amended by changing the Zoning Class of Lot 2 District Lot 4598 Kootenay Land District EPP75763 (PID 030-260-191) shown on Schedule ‘A’ from Ootischenia Suburban Residential (R1A) to Ootischenia Suburban Residential ‘s’ (R1As) as shown on the attached map.
- 4** This Bylaw shall come into force and effect upon its adoption.

CITATION

- 5** This Bylaw may be cited as **“Regional District of Central Kootenay Zoning Amendment Bylaw No. (TBD), 2022.”**

READ A FIRST TIME this day of , 202X.

READ A SECOND TIME this day of , 202X.

WHEREAS A PUBLIC HEARING was held this day of , 202X

READ A THIRD TIME this day of , 202X.

ADOPTED this [Date] day of [Month] , 20XX.

Board Chair

Corporate Officer